

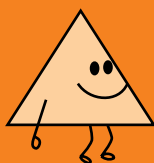

HANDS-ON MATHS



Arvind Gupta

Illustrations: Reshma Barve

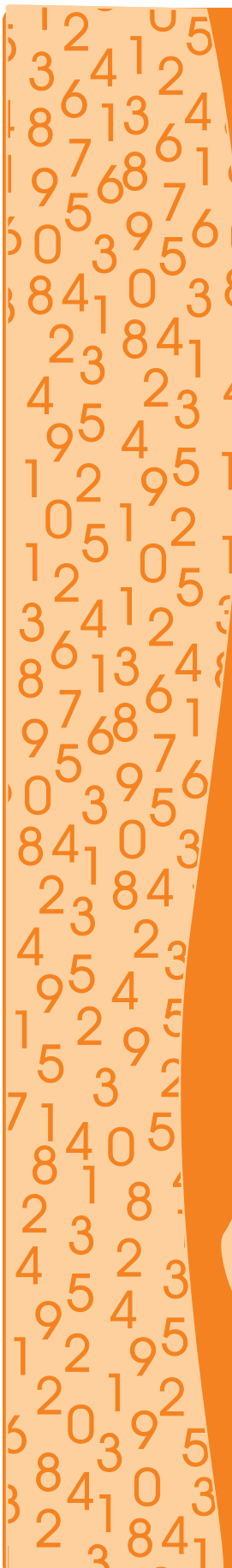
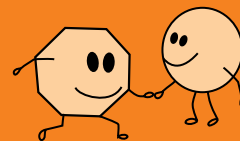
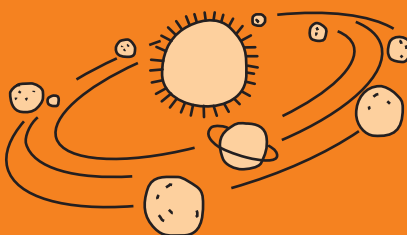
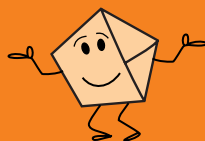

HANDS-ON MATHS

Arvind Gupta graduated from the Indian Institute of Technology, Kanpur (1975) with a degree in Electrical Engineering. He has written 20 books on science activities, translated 150 books into Hindi and presented 125 films on science activities on Doordarshan. His first book *Matchstick Models & Other Science Experiments* was translated into 12 Indian languages and sold over half a million copies. He has received several honours, including the inaugural National Award for Science Popularization amongst Children (1988), Distinguished Alumnus Award of IIT, Kanpur (2000), Indira Gandhi Award for Science Popularization (2008) and the Third World Academy of Science Award (2010) for making science interesting for children. Currently he works at Inter-University Centre for Astronomy and Astrophysics's Children's Science Centre, Pune, and shares his passion for books and toys through his popular website <http://arvindguptatoys.com>.

Reshma Barve studied Commercial Arts at the Abhinav Kala Mahavidyalaya, Pune. She is a freelance artist and designer and has illustrated many children's books.



Arvind Gupta

Illustrations: **Reshma Barve**

Dedicated to Dr. Vinod Raina
who sowed seeds of hope

Text © 2015 Arvind Gupta
Illustrations © Reshma Barve

This book was developed under a grant from the
Sir Ratan Tata Trust.

All rights reserved.

Published by Scholastic India Pvt. Ltd.
A subsidiary of Scholastic Inc., New York, 10012 (USA).
Publishers since 1920, with international operations in Canada,
Australia, New Zealand, the United Kingdom, India, and Hong Kong.

No part of this publication may be reproduced in whole or in part, or
stored in a retrieval system, or transmitted in any form or by any means,
electronic, mechanical, photocopying, recording, or otherwise without the
written permission of the publisher.

For information regarding permission, write to:
Scholastic India Pvt. Ltd.
A-27, Ground Floor, Bharti Sigma Centre
Infocity-1, Sector 34, Gurgaon 122001 (India)

This edition: February 2015

ISBN-13: 978-93-5103-XXXXX

Contents

Preface	1
Real Life Math	2
Add From One to Hundred	4
Linking Them Together	5
Lilavati: Poetry in Maths	6
Anno's Magic Seeds	8
Ramanujan: The Mathematical Genius	10
Mollakka's Horse	11
Kaprekar's Constant: 6174	12
Following Instructions	13
Geometry by Paper Folding	14
Symbols and Spaces	14
Mathematical Rigour	15
Odd and Even	15
P. K. Srinivasan: The Math Missionary	16
Folding a Pentagon	18
Folding an Equilateral Triangle	18
Folding a Diamond	19
Folding an Octagon	19
Making a Cross	20
Folding a Hexagon	20
Angles of a Triangle/Quadrilateral	21
Paper Protractor	22
Number Friends	22
Paper Patterns	23
Drawing a Circle	23
Kaleidoscope	24
Fantastic Flexagon	25
Paper Ball	26
Strip Tetra	27
Broomstick Structures	27
Self Locking Cube	28
Cryptograms	29
Tessellations	30
Folk Art of Kolam	30
Simple Tessellations	31
Square Up!	31

The Height of It!32
Place Value Snake32
Diagonal of a Brick33
Catching Crooks33
Maps and Surveys33
Which Holds More?34
Understanding the Universe34
Thinking Outside the Box35
Number Patterns with Dots35
Cats and Mats36
Palindrome37
Simple Conservation38
Remembering the Value of Pi38
Parts of a Circle39
Which Holds More?39
A Tricky Circle40
Add to 10040
Measuring Out40
How Many Days in February?40
Legend of the Chess-Board41
Mathematical Proof42
Mirror Puzzles43
Shortest Path44
Postman's Problem45
Matchstick Matching46
Tangram47
Value of Pi48
Biggest Box49
Fun with Dices51
Birthdays52
Perforated Symmetry53
Maths Graphics53
Finger Multiplication54
The Earth's Circumference55
Cylinder-Cone Volume56
Square to Triangle56
Solutions to Matchstick Matching57

PREFACE

Mathematical thinking is an important way of solving real world problems. Math enables us to see every day problems quantitatively:

“Should I put my money in a bank fixed deposit (FDs) or fixed maturity plan (FMPs)—or invest it in the stock market?”
“What is the best and shortest route for a newspaper boy?”

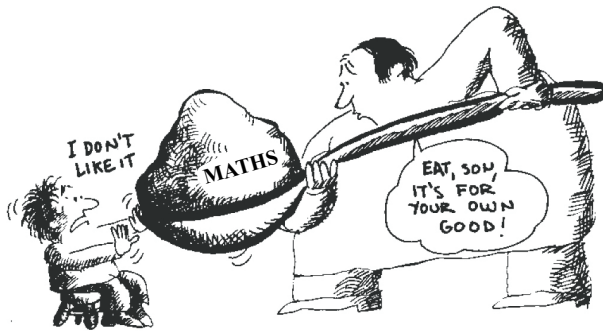

Pix: Danger School

We need more quantitative thinking now than ever before. But schools seldom present math in real-world terms. In most math classes children are confronted with contrived, uninteresting problems. They mechanically go through this grind of solving bookish problems and never get to the bigger picture of using math in the real-world context.

Math has been reduced to simple computation, divorced from its larger purpose and removed from its practical applications. Is it any surprise that many smart people conclude math isn't for them? We tend to forget that early mathematics evolved from the work of the tailor and the tinkerer—all practical crafts people. Mathematics has deep roots in practice. The very vocabulary of mathematics is replete with associations of its pragmatic past. Consider, for instance, the word “straight line”, which comes from the Latin “stretched linen”. Any farmer wanting to grow potatoes would simply stretch a string to help him sow in a straight line. Any mason would simply stretch a piece of string to enable him to lay bricks in a straight line. So, over time “stretched linen” became “straight line”. The “digits” 1 to 10, which we use so commonly come from the Latin word for fingers—the 10 fingers of our hands.

It is time school mathematics was rescued from its mumbo-jumbo and made more effective and authentic to its purpose. Computers offer powerful tools in solving complex numeric problems. A Calculus class should be about solving problems in the real world of engineering—to build smarter bridges and houses. Mathematics will be much more interesting and engaging for students if it mimicked the real world and helped solve some practical problems.

Children need to solve a wide variety of puzzles and teasers—in short, learn maths the fun way. They need to experiment with real things. This book documents a few interesting math stories and activities.

REAL LIFE MATH

Dr. Abhay Bang is an iconic doctor. As a Community Health Activist he has worked with the most marginalised indigenous communities in India. As a child he studied at the Nai Taleem (Basic Education) School set up by Gandhiji at Wardha.



Here Dr. Bang recounts the fascinating story of how he learnt real life math—not by solving bookish problems but by actually constructing a water tank for cows in his school.



Here is a typical bookish maths problem.
"There is a water tank with two taps. One tap fills the tank, the other drains it out. How long will it take to fill up the tank?"

Maths books are replete with such mundane questions. Any clever person can easily solve the problem by closing the lower tap!
I will give an example how I learnt the concept of volume in my school."



The moot question is: Is there any link between mathematics and real life experiences?



We had to do three hours of constructive work every day. This was part of Gandhiji's philosophy of "Bread Labour" where children worked in the fields to grow their own food.

It was also part of **Vinoba Bhave's** vision of gaining various skills by engaging in socially useful productive work.



For this I had to work for a few days in the newly constructed cowshed. My teacher assigned me a very specific practical problem.

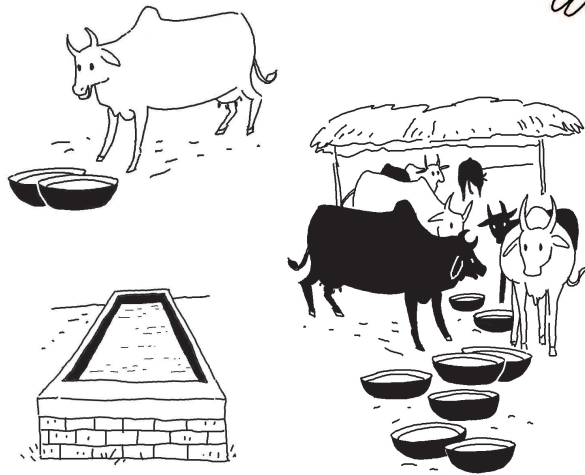
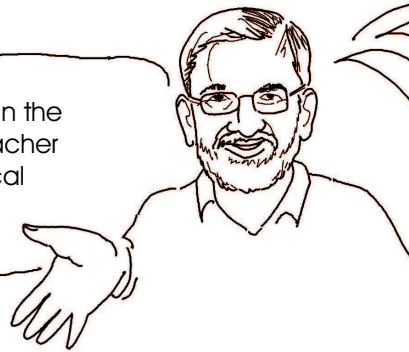

I had to find the amount of water a cow drinks in a day. How much water would be needed for all the cows in the cowshed? Then construct a water tank with the capacity to satiate the thirst of all the cows.

For this I had to figure out the number of bricks needed to construct such a tank. Then go to the market and buy the bricks. For over a week I grappled with this real-life mathematical problem.

There were numerous tanks with varying sizes. How to measure their volume? What was the relationship between the volume and the outer surface area of the tank? Finally, I actually constructed the water tank and in the process learnt a great deal of real-life mathematics.



ADD FROM ONE TO HUNDRED

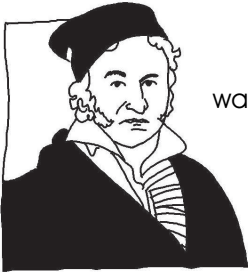

Carl Friedrich Gauss (1777—1855) was the prince amongst mathematicians. Born in a poor family in Germany he showed immense talent for mathematics at a very young age.

One day as his father calculated the wages of his workers little Carl looked on.

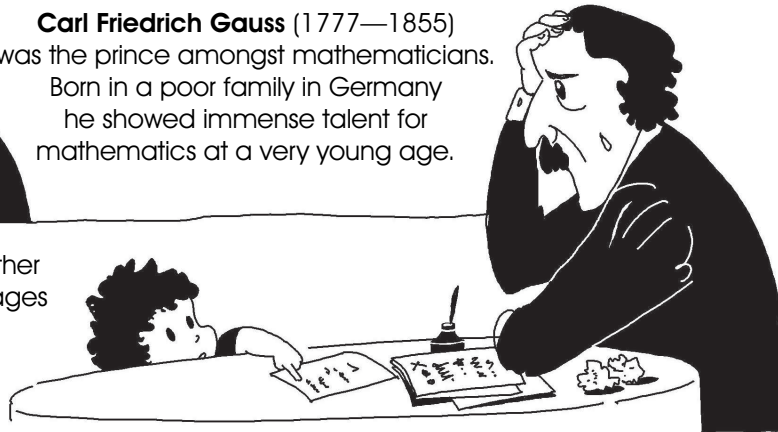

Later he told his father that the answer was wrong and told him the right way to calculate it. His father re-calculated and found Carl was correct. No one had taught Carl how to calculate, he just listened and learnt.



There is another famous story from Gauss's schooldays. When he was ten years old, Master Buttner asked the students to write down the numbers from 1 to 100 and then add all of them up. The children wrote down the numbers on their slates and started to add them up. It was easy to add the first few numbers as they were small. But as they went to two digit and higher numbers the going became slow. All the while that the other children were frantically adding, Carl looked intently at the numbers. As he peered at the numbers with rapt attention he saw an amazing pattern.



While the other students toiled on for the rest of the hour, Carl sat with folded hands under the scornful and sarcastic gaze of Master Buttner.

At the end of the period, Carl alone had got the correct answer. Upon inquiry Carl explained how he had arrived at his result.

In a flash, Carl wrote the answer 5050 on his slate.

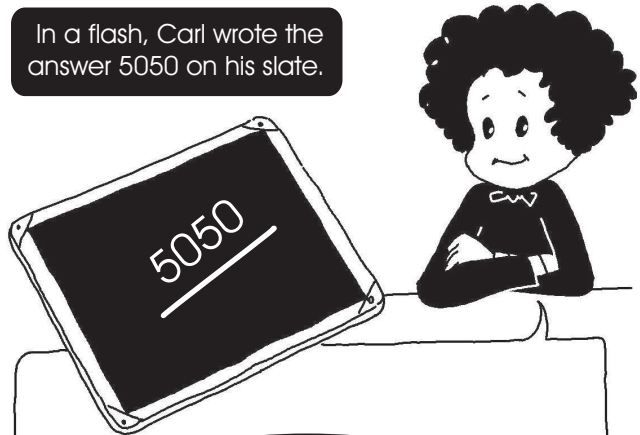

Seeing patterns makes things much simpler.

$$1 + 2 + 3 + \dots + 98 + 99 + 100$$

I looked at the first and the last number. And their sum was $100 + 1 = 101$. Then I looked at the second and the second last number. Their sum was also 101 ($2 + 99 = 101$). The sum of the third and the third last number was also 101 ($3 + 98 = 101$). This pattern extended to the whole series. I reckoned as there were only 100 numbers there would be fifty such pairs—each adding to 101. So I simply multiplied 101 by 50 and got 5050.

LINKING THEM TOGETHER

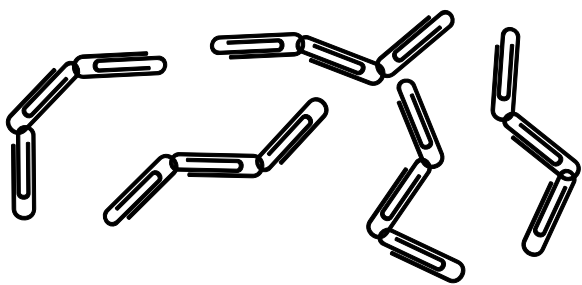

These 15 links are to be joined into one long chain. It costs one-rupee to cut a link and two-rupees to weld a link together.

What is the cheapest way to make the chain?

LILAVATI – POETRY IN MATHS

In his famous book *Lilavati*, **Bhaskaracharya** (1114-1183) claimed that the division of a quantity by zero is an infinite quantity “which does not change when worlds are created or destroyed.”



Mathematics is often portrayed as a complex, dry subject with abstract reasoning that may appeal to only a select few. *Lilavati*, a mathematical treatise by the Indian mathematician Bhaskaracharya, corrects that impression by presenting the reader with attractive problems poetically described and relating to contemporary life.

Consider the following example:

The square root of half the total number of a swarm of bees went to a Malati tree, followed by another $\frac{8}{9}$ th of the total. One bee was trapped inside a lotus flower, while his mate came humming in response to his call. O Lady, tell me how many bees were there in all?

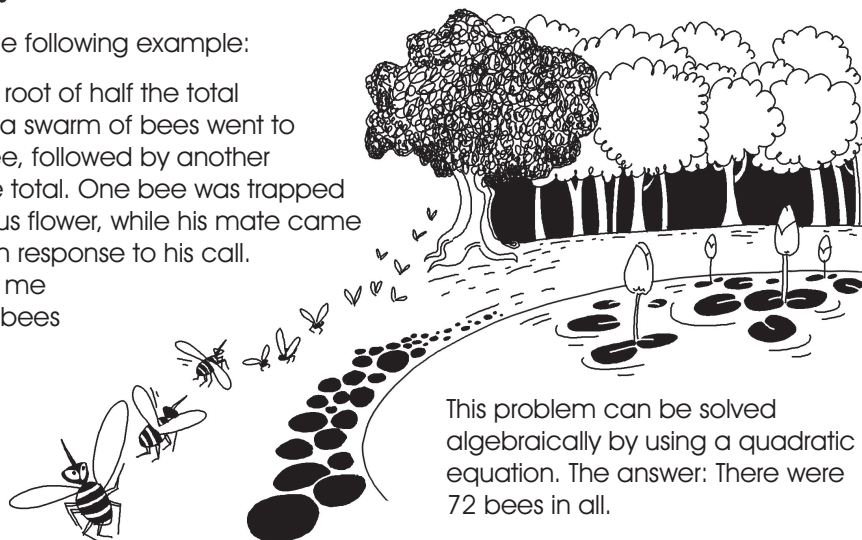

This problem can be solved algebraically by using a quadratic equation. The answer: There were 72 bees in all.

It is said that Bhaskaracharya wrote these problems to get his daughter Lilavati interested in mathematics. Bhaskara studied Lilavati's horoscope and predicted that her husband would die soon after the marriage if the marriage did not take place at an auspicious time.

To alert Lilavati of the correct time, he placed a cup with a small hole in its base in a vessel of water. The cup would sink at the beginning of the propitious hour. Bhaskara hid the device in a room with a warning to Lilavati to not go near it. The curious Lilavati could not resist the temptation and sneaked in the room to look at the device. Just then a pearl from her nose ring accidentally dropped into the cup, upsetting it. Because the marriage took place at the wrong time Lilavati was soon widowed.

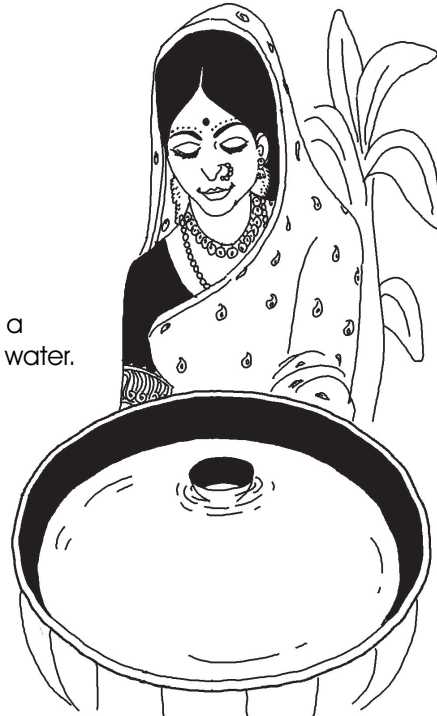

Here is another pearl of a problem:

A necklace broke.
A row of pearls mislaid.
One-sixth fell to the floor.
One-fifth upon the bed.
The young woman saved one third of them.
One-tenth were caught by someone else.
If six pearls remained upon the string
How many pearls were there altogether?

ANNO'S MAGIC SEEDS

Anno's Magic Seed is a rare book. It weaves the magic of math in a gripping story. It was written by the celebrated Japanese author **Mitsumasa Anno** (b 1926). Anno won the coveted Hans Christian Anderson Award in 1984 for his extraordinary books.

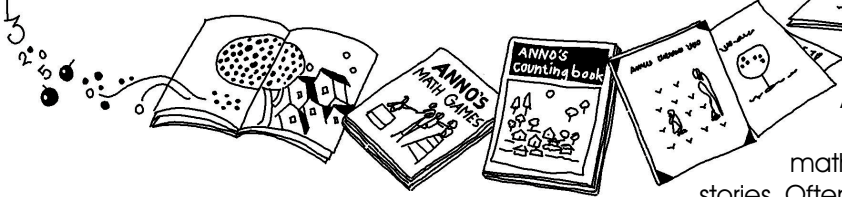

Anno weaves sophisticated mathematics into stories. Often one doesn't know whether it's the math which is driving the story or the story which is pushing the math.

Jack is a good for nothing lazy bum. One day he meets a wise old man. The magic begins when the wizard gives Jack two magic golden seeds. Jack eats one and, miraculously, isn't hungry for a whole year! He buries the other seed, just as the wizard had told him to do and the plant yields two seeds. One seed keeps Jack's tummy full for a year. He plants the other seed. Each plant always bears two seeds. So every year Jack eats one seed and plants the other.

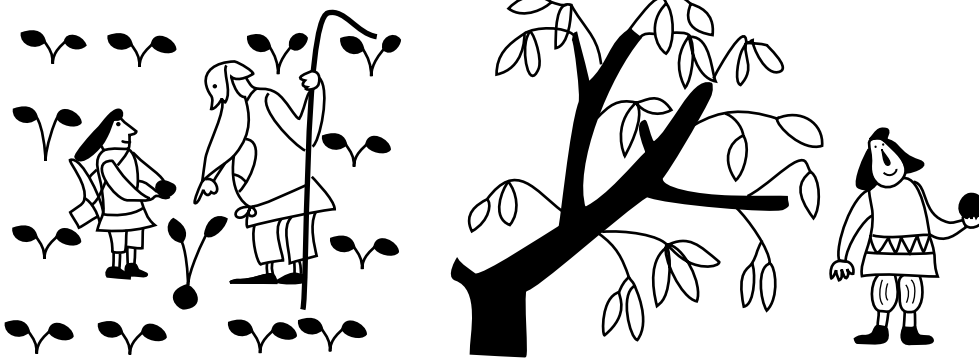

Years pass away in bliss. But one year Jack decides to find food elsewhere and plants both seeds instead of just one. Next year he gets 4 seeds: he eats 1 and plants 3. Next year he gets a crop of 6; eats 1 and plants 5. His store of seeds grows and he becomes rich.

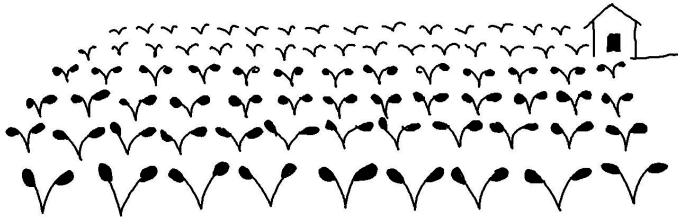

Later Jack gets married and has a child. He not only feeds his family but soon his fortune grows by ones and twos, then faster and faster until he becomes very rich. Then a terrible flood threatens to take it all away.

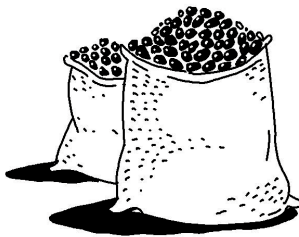

Jack and his family loose all their fortune to the vagaries of nature. A devastating flood washes away everything. Just a few magic seeds remain tied to the branch of a tree. Jack, his wife and child bow to God for saving there lives and start all over again.

This many-layered tale is much more than just an entertaining mathematical story. It has a deeper message. Visual clues reveal the moment when carefree Jack mends his lazy ways; perceptive viewers will detect at what point Jack becomes smarter (or perhaps more calculating). In the end, a wiser Jack finds the courage to start it all again. Here is a heartening message for readers of all ages. This story mirrors many events from the real world. Adversity and poverty is followed by prosperity. The change of fortune leads to great success. But finally a natural disaster threatens to wipe out all the riches and is deeply humbling.

Solutions to Cryptograms on Page 29

1. S = 1, O = 7, I = 3, L = 4, B = 6, Y = 2.
2. S = 3, L = 0, Y = 6, R = 5, I = 9, G = 1.
3. C = 1, R = 4, A = 9, B = 5, S = 0.
4. M = 4, E = 6, A = 2, L = 1, S = 5.
5. T = 9, E = 0, P = 1, I = 5, L = 7.
6. P = 8, E = 1, N = 3, R = 6.
7. D = 8, O = 4, G = 9, F = 1, A = 0, N = 2, S = 7.
8. H = 9, O = 3, T = 2.
9. L = 6, U = 7, S = 1, H = 9, E = 0, R = 5.
10. S = 5, P = 9, I = 4, T = 6.
11. T = 2, A = 5, P = 8, E = 6.
12. S = 9, E = 5, N = 6, D = 7, M = 1, O = 0, R = 8, Y = 2.
13. W = 0, I = 6, N = 2, L = 5, A = 7, S = 8, T = 9.
14. A = 4, H = 6, O = 2, G = 5, T = 1, I = 0, E = 7.
15. O = 6, N = 9, E = 3, R = 8, Z = 1.
16. T = 7, H = 5, I = 3, S = 0, V = 1, E = 9, R = 4, Y = 2, A = 5.
17. C = 9, R = 6, O = 2, S = 3, A = 5, D = 1, N = 8, G = 7, E = 4.
18. M = 1, E = 3, T = 7, R = 4, L = 6, I = 9, G = 5, A = 0, S = 2, C = 8.
19. J = 8, U = 4, N = 3, E = 2, L = 7, Y = 5, A = 1, P = 6, R = 9, I = 0.
20. FIND OUT FOR YOURSELF!

RAMANUJAN: THE MATHEMATICAL GENIUS



Srinivasa Ramanujan was born on December 22, 1887 in Erode, Tamil Nadu, His father worked as a clerk in a sari shop. Ramanujan was a child prodigy and showed a flair for maths very early on. He always asked questions ... sometimes unusual ones like. "How long would it take for a steam train to reach Alpha Centauri?" This didn't endear him to his teacher.

One day the teacher explained division saying "If you divide any number by itself, you get 1."
"Is zero divided by zero also equal to one?" Ramanujan asked.

Ramanujan was a mathematical prodigy; he did not have a formal training in mathematics. Yet Ramanujan produced gems in number theory. When **Paul Erdos** asked **G. H. Hardy**, what was his greatest contribution to mathematics? Without hesitation Hardy replied that it was finding Ramanujan. Though Hardy was an atheist and would always ask for a rigorous proof, Ramanujan would sometimes jot down proofs based purely on intuition.



Ramanujan was awarded a Bachelor of Science degree by Cambridge in 1916 and was made a Fellow of the Royal Society (FRS) in 1919. Being a strict vegetarian he would cook his own food. Perhaps, due to intense work pressure and lack of proper diet, he contracted tuberculosis in England and was admitted to a nursing home.

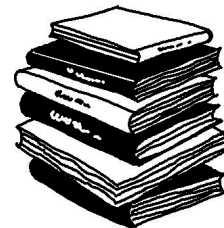

D. D. Kosambi
(Eminent Indian
Mathematician)

"Our country has produced only one mathematician of the first rank after Bhaskaracharya 800 years ago. This was Ramanujan and he was unable to pass even the first year of college. India gave him birth, starvation, tuberculosis, and a premature death. It is to the everlasting credit of the English mathematician Hardy that he recognised the merit of one who was considered half made by the Indians, had him brought in England, trained him, and brought out his splendid ability."

While visiting Ramanujan in the nursing home Hardy remarked, "The number of my Taxicab was 1729, it seemed to me a rather dull number."

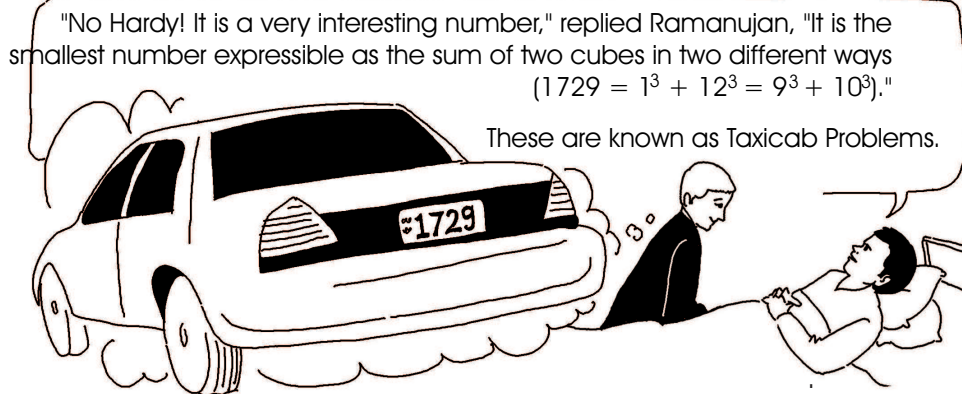

MOLLAKKA'S HORSE

Once upon a time there lived a businessman. He had three sons. None of them were interested in his business. The transactions were carried out by his manager. Accidentally one day he fell ill. In his last days he prepared a will, which mentioned that half of his property should go to the first son. Half of the remaining should go to the second; and half of the remaining should go to the third. After his death they realised that their father left them only 7 horses. In order to divide the property as in the will, they would have to cut the horses. So they were in a deep dilemma.

Then a wise man called 'Mollakka' came to help them. He first gave his horse to them—as a gift, after which the total inheritance became 8 horses. As mentioned in the will, the first son got half of the total, i.e. 4 horses; the second son got half of the remaining 4, i.e. 2 horses and the third son got half of the remaining 2, i.e. 1 horse. All together they got $4 + 2 + 1 = 7$ horses. Mollakka returned home riding his own horse.

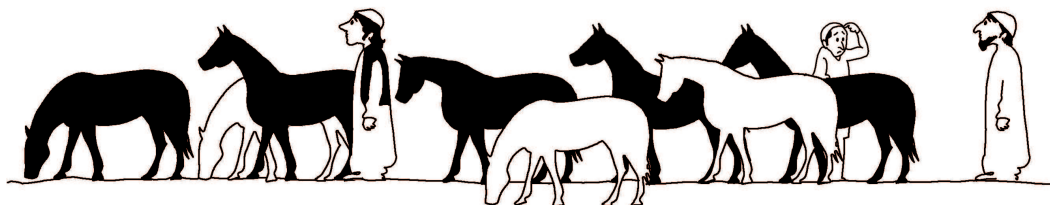

KAPREKAR'S CONSTANT - 6174



Dattaraya Ramchandra Kaprekar

(1905–1986) was an Indian mathematician who discovered several interesting results in number theory, including a class of numbers and a constant named after him. Kaprekar had no formal postgraduate training and worked as a school teacher through his entire career (1930-1962), in Nashik, Maharashtra.

He published extensively, about recurring decimals, magic squares, and integers with special properties. Soon he became well known in recreational mathematics circles. Working largely alone, Kaprekar discovered a number of results in number theory and described various properties of numbers. Initially his ideas were not taken seriously by Indian mathematicians, and his results were published privately and also largely in low-level mathematics journals.

International fame arrived when **Martin Gardner** wrote about Kaprekar in his March 1975 column on mathematical games for the *Scientific American* magazine. Today his name is well-known and many other mathematicians have pursued his work. He discovered the Kaprekar constant—6174—in the year 1949.



First choose a four digit number where the digits are not all the same (that is not 1111, 2222...). Then rearrange the digits to get the largest and smallest numbers these digits can make. Finally, subtract the smallest number from the largest to get a new number, and carry on repeating the operation for each new number.

Let us try number 2013. The maximum will be 3210 and the minimum will be 0123

$$3210 - 0123 = 3087$$

$$8730 - 0378 = 8352$$

$$8532 - 2358 = 6174$$

$$7641 - 1467 = 6174$$

When we reach 6174 the operation repeats itself, returning 6174 every time.

We call the number 6174 a "kernel" of this operation. So 6174 is a kernel for Kaprekar's operation, but this is as special as 6174 gets.

In 1949, Kaprekar discovered the CONSTANT 6174 which is named after him.

6174 is reached in the limit as one repeatedly subtracts the highest and lowest numbers that can be constructed from a set of four digits that are not all identical. Thus, starting with 1234, we have ...

$$4321 - 1234 = 3087, \text{ then}$$
$$8730 - 0378 = 8352, \text{ and}$$
$$8532 - 2358 = \mathbf{6174}$$

Repeating from this point onward leaves the same number ($7641 - 1467 = 6174$).

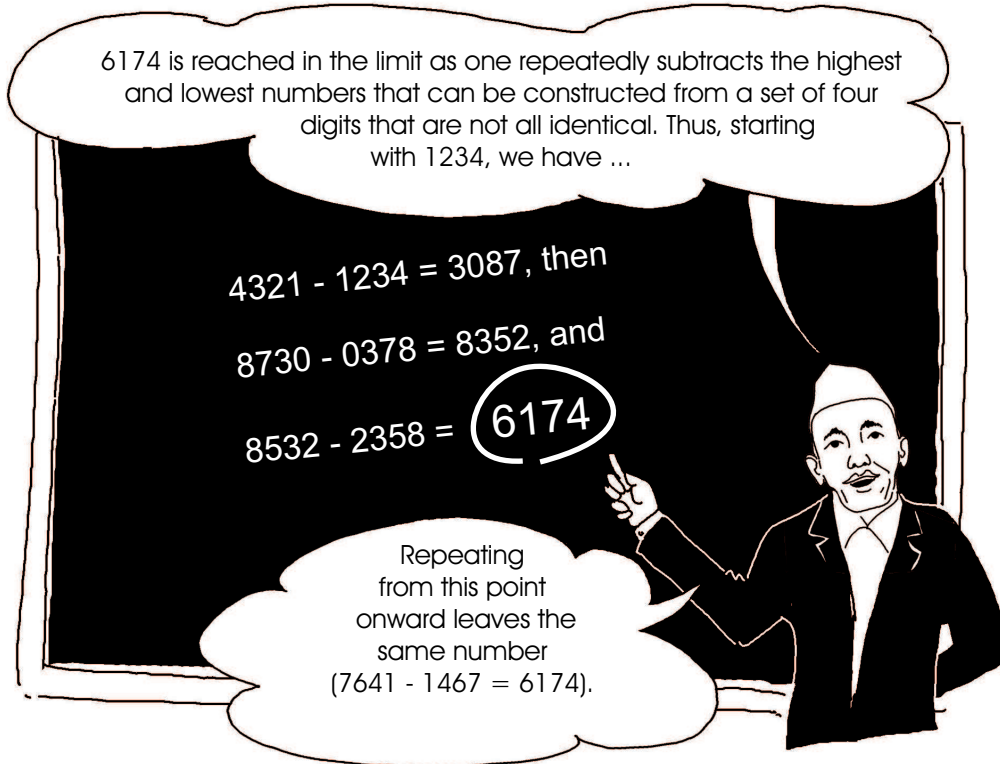

FOLLOWING INSTRUCTIONS

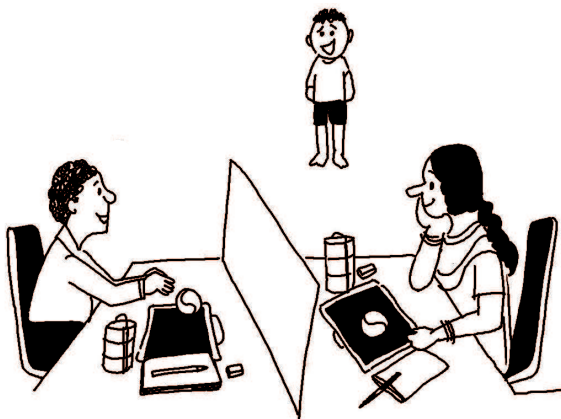

How good are we at giving precise instructions? Two players sit across a table with a screen in between. Both have the same set of objects. The girl puts the things one-by-one in a particular pattern. She explains her actions to her partner.

Her partner cannot see her arrangement but has to follow her instructions and make a similar arrangement. This is often not very easy to do. You will be surprised at the goof ups!

GEOMETRY BY PAPER FOLDING

India gave the world the Zero is well known. However, few know that the first book on learning geometry through paper folding - Origami was written by an Indian—**Tandalam Sundara Row**.

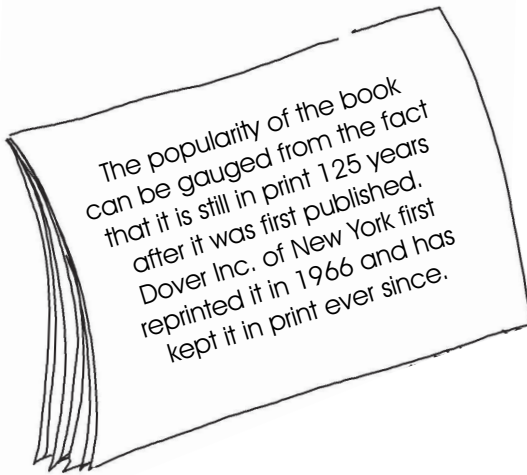
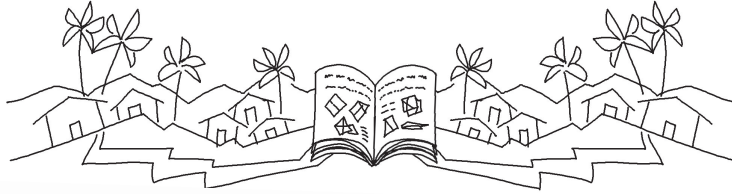

His book *Geometric Exercises in Paper Folding* was first published in 1893, by Addison & Co, Mount Road, Madras (Chennai).

Those were British days and it is logical to assume that the Rao in T. Sundara Rao was anglicised to Row. Little is known about this enigmatic genius but for the fact that he did a B. A. and was a Deputy Collector somewhere in Tamil Nadu.

SYMBOLS AND SPACES

About 5,000 years ago in Babylonia, located in modern day Iraq, people counted in 60s. They used 59 different symbols for numbers 1-59 and left a space for zero. For bigger numbers, each symbol's position stood for groups of 60s, or 60×60 , and so on.

This whole inscription symbolizes 72. The first symbol stands for one group of 60. The next three symbols represent 12 units. This counting system still survives in the way hours are divided into 60 minutes, and minutes into 60 seconds.



MATHEMATICAL RIGOUR

This story told by **Ian Stewart** highlights the rigour in mathematics. An astronomer, a physicist, and a mathematician were holidaying in Scotland. In the countryside they observed a black sheep in the middle of a field.

"How interesting", observed the astronomer, "All Scottish sheep are black!" To which the physicist responded, "No, no! Some Scottish sheep are black!" The mathematician gazed heavenward in supplication, and then intoned, "In Scotland there exists at least one field, containing at least one sheep, at least one side of which is black!"



ODD AND EVEN

*If you are an even number,
You always have a pair.
So if you look around,
Your buddy will always be there.*

*But if you are an odd number,
There's always a lonely one.
He looks around to find his buddy,
But he's the only one.*

- Marg Wadsworth

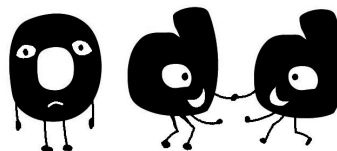
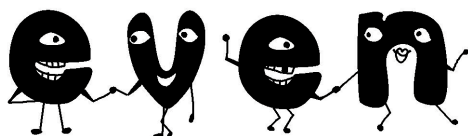

MATH MISSIONARY - P. K. SRINIVASAN



I first heard about T. Sundara Row's epic book *Geometric Exercises in Paper Folding* from **P. K. Srinivasan** (PKS) (1924-2005). PKS was the greatest proponent in India of learning mathematics through activities.

PKS breathed maths. He dreamt maths. More than anything else he rubbed this infectious enthusiasm on anyone who crossed his path. In 1986, I first met him in a workshop organised by the Sri Aurobindo Ashram at Puducherry.

Those were pre-Xerox days. So, PKS summoned a ream of cyclostyling sheets, scissors, glue, old newspapers and one lone stapler. Every teacher was given one sheet of paper and asked to fold an angle of sixty degrees.

The teachers were at sea!
Schooled into drawing angles
only with a protractor they
didn't know of any other way.
Soon the teachers gave up.

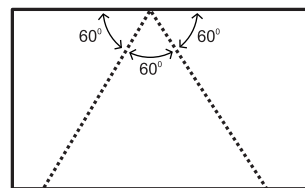
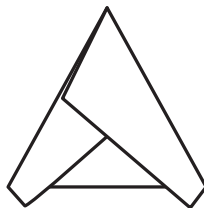

Then PKS folded one straight edge (180-degrees) into three equal parts and produced an exact 60-degree angle! The teacher's were amazed. It was almost like a revelation— all so elegant and beautiful.



The whole day the teachers folded geometric shapes—rhombus, hexagon, octagon etc. They folded over 80 2-D and 3-D shapes. They learnt more about practical geometry in this two-day workshop than they did in their entire B. Ed. course.

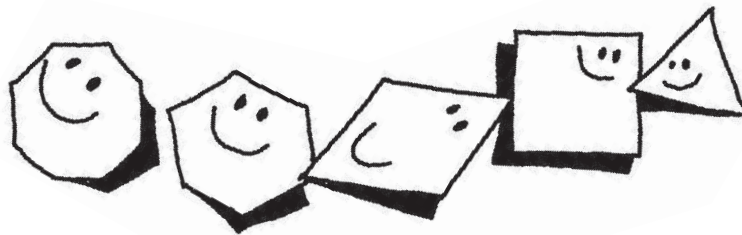

As a one man math missionary P. K. Srinivasan did more than anyone else to imbue children with the love of this most beautiful subject mathematics—the queen of all sciences. He cried, he wept and pleaded with one and all that mathematics was all around them. And when no one listened he wrote a series of 60 articles for *The Hindu* newspaper which have become classics. He showed that there was mathematics in coins, in broomsticks, in matchboxes, in the square copy, in bus tickets, in the calendar and in every ordinary thing around us. These articles have been collated and published as a book—*Resource Material for Mathematics Club Activities* by the NCERT.

PK Srinivasan's other books—*Number Fun With a Calendar* and *Romping in Numberland*—have been translated and published in several Indian languages.

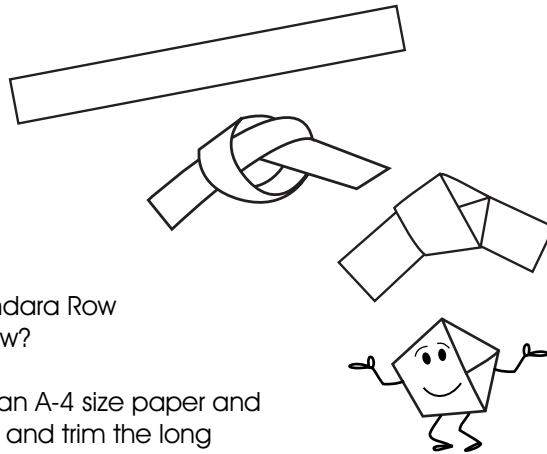

How does one fold a pentagon?
It is tricky but easy. In 1893, T. Sundara Row demonstrated this beautifully. How?

Cut a long 3 cm wide strip from an A-4 size paper and simply tie a knot. Flatten the knot and trim the long ends to get a regular Pentagon. How many times have we tied knots yet never noticed this!

FOLDING AN EQUILATERAL TRIANGLE

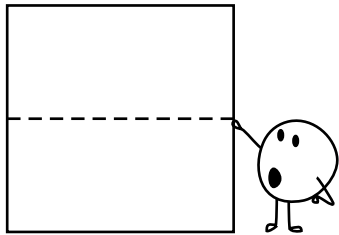

Fold the mid-line of a square.

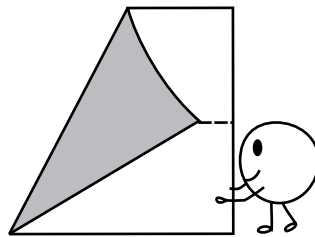

Place the top left corner on the mid-line. Crease such that the left edge passes through the bottom left corner.

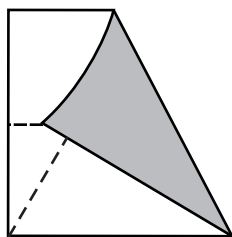

Repeat the same with the top right corner.

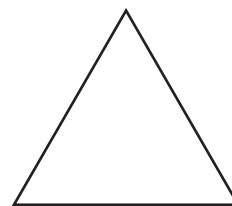
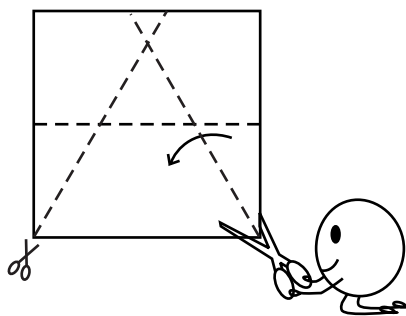

Cut along the two dotted lines ... to see an elegant Equilateral Triangle!

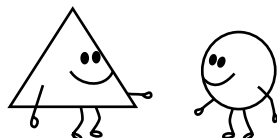

FOLDING A DIAMOND

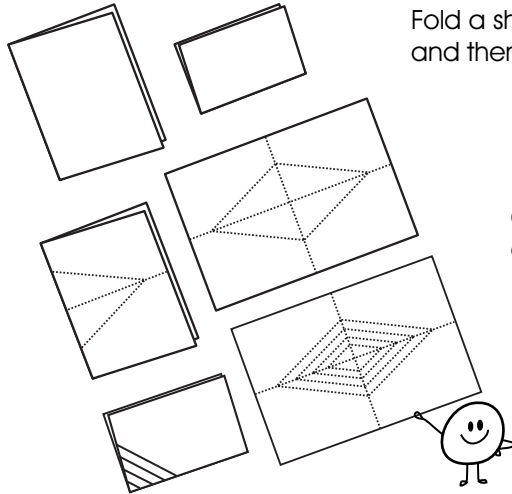

Fold a sheet first into half and then into quarter.

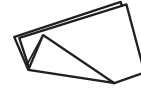

Crease the triangle at the four fold corner.

On opening the sheet you will see an elegant Rhombus in the middle.

Make several parallel creases. On opening you will see a diamond in a diamond in a diamond.

FOLDING AN OCTAGON

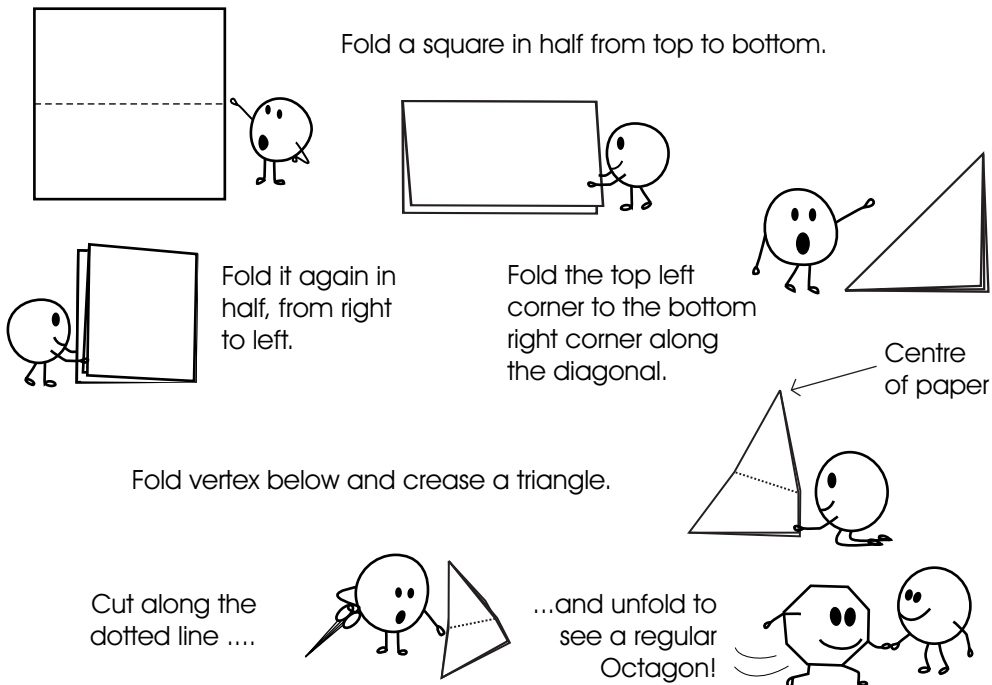

Fold a square in half from top to bottom.

Fold it again in half, from right to left.

Fold the top left corner to the bottom right corner along the diagonal.

Fold vertex below and crease a triangle.

Cut along the dotted line

...and unfold to see a regular Octagon!

MAKING A CROSS

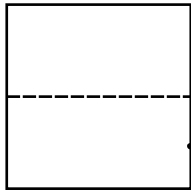

Fold a square in half from bottom to top.

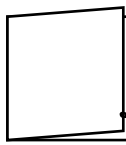

Fold in half from left to right.



Fold the upper layer diagonally in half. Turn over and do the same behind.

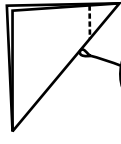
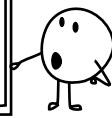
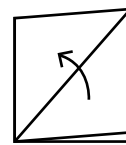

Cut along dotted line...

...and unfold to see a CROSS!

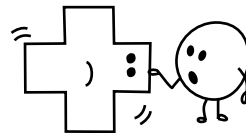

FOLDING A HEXAGON

Fold a sheet into half.

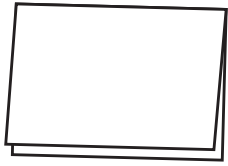

Fold the doubled up straight edge (180-degrees) into three equal parts of 60-degrees each..

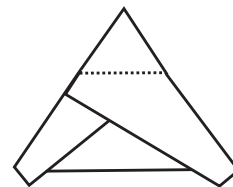
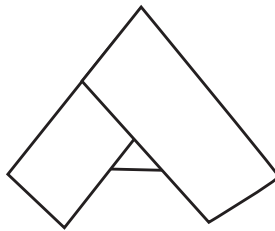

Fold a triangle from the apex point. On opening the paper you will see a regular Hexagon in the middle.

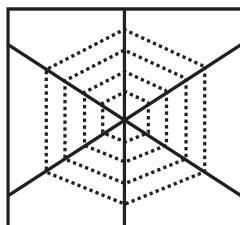
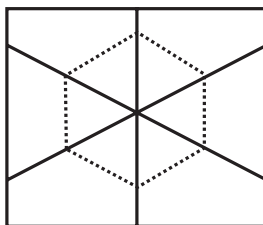

If you crease several triangles then on opening the paper you will see a Hexagonal Cobweb in the center.

ANGLES OF A TRIANGLE

Take a paper—white on one side and coloured on the other. Cut a triangle ABC of any shape.

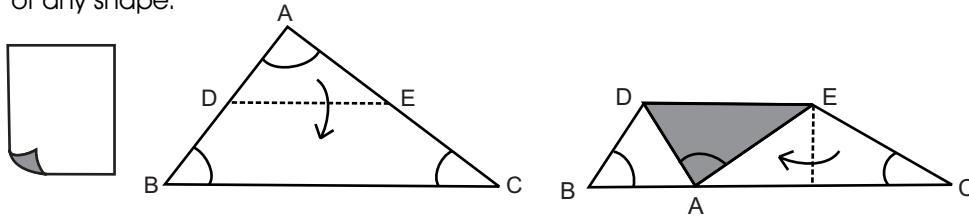

Fold apex A to touch base BC. Then fold the left and right angles

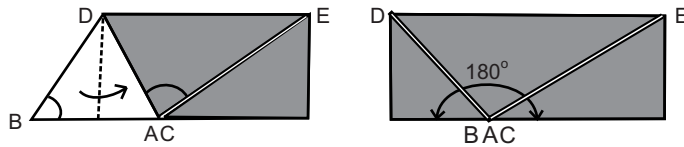

You will find that all the three angles of the triangle neatly come together and make a straight line—an angle of 180 degrees.

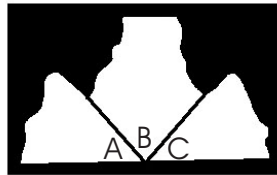
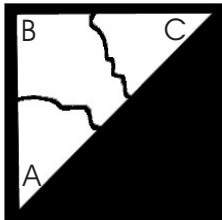

Tear a triangle into three parts and then bring the three angles together to make 180 degrees.

ANGLES OF A QUADRILATERAL

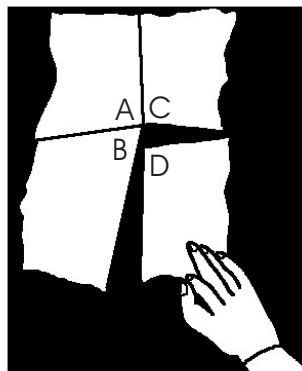
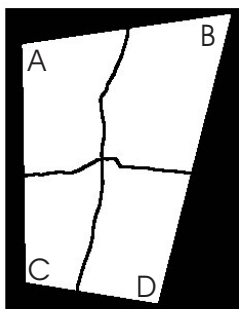

Take any four-sided quadrilateral. Tear it as shown into four parts. Then bring the four corners of the quadrilateral together. They will snug into each other and add up to 360 degrees. Try this exercise with different shapes of quadrilaterals.

PAPER PROTRACTOR

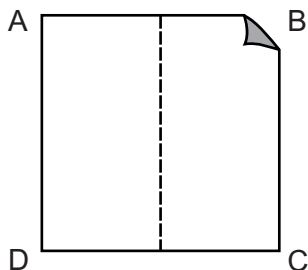

1. Fold mid-line of a 10 cm paper square (ABCD).

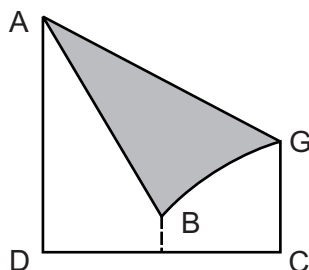

2. Place corner B on mid-line and pass it through corner A.

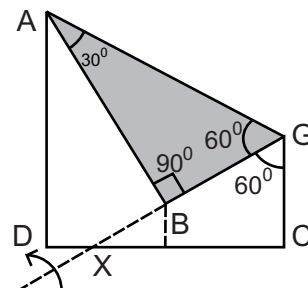

3. Angle AGB will be 60-degrees. As angle ABG is right angled so angle BAG will be 30 degrees. Lift and tuck lower flap along GX.

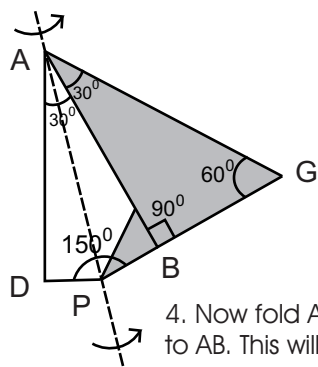

4. Now fold AD to AB. This will bisect angle DAB.

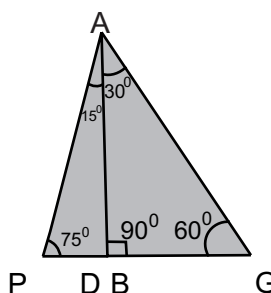

5. This paper protractor can measure angles of 15, 30, 45, 60, 75 and 90 degrees. So, next time if you forget your protractor, just fold one!

NUMBER FRIENDS



Ancient Greek mathematician **Pythagoras** founded a community called the Pythagorean Order. Its members believed numbers could explain everything in the world. The two numbers they especially liked were 220 and 284. If you add up the factors of 220 (except 1 and 220), you get 284. And if you add up the factors of 284 (except 1 and 284), it makes 220. Because they shared this strange link Pythagoreans called them Amicable Numbers.

PAPER PATTERNS

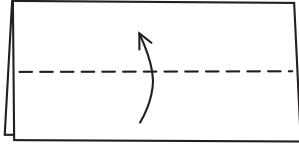

1. Fold a sheet of coloured paper in half. Then fold the top layer of the bottom edge up to the folded edge. Turn over and do the same behind.

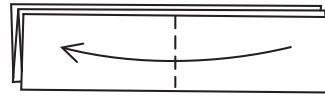

2. Fold the right edge to the left edge.



3. Fold the top layer of the left edge to the folded edge. Turn over and repeat to get a square with 16 layers.

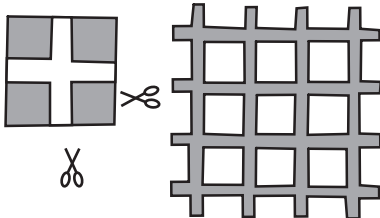

4. Cut away each corner of the little square, to create a grill (jaali) like pattern.



5. By cutting off the shaded parts you will get a more complex pattern.

DRAWING A CIRCLE

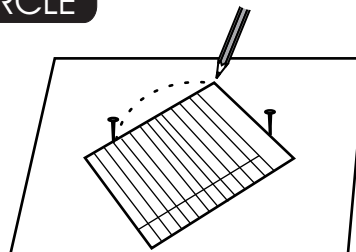
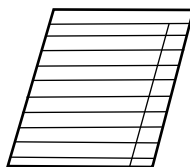

Here is an unusual way of drawing a circle. Take a rectangular piece of paper. Place two pins, 4 cm apart, on a piece of board. Place one edge of the paper (the right angle) between the two pins. Mark a dot at the right angle.

Now keep moving the paper in a circular motion, marking dots. Join these to make a perfect semicircle. Just make sure that the sides of the paper are touching the two pins at all times. After completing the semicircle, point the right angle the other way and complete the circle.

KALEIDOSCOPE

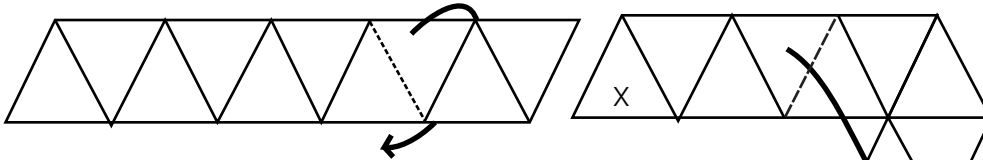

1. With a protractor, make a strip of 10 equilateral triangles; of side length 5-cm. Mountain fold the marked line.

2. Valley fold where shown. X goes beneath Y.

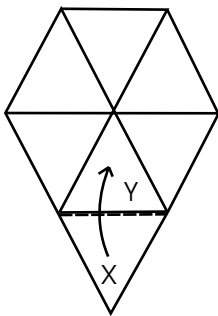

3. Glue triangle X, then valley fold it onto Y, to stick them together.

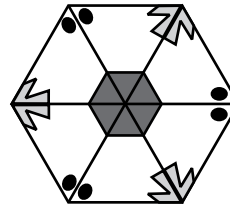

4. The Kaleidoscope is now complete. Decorate as shown, or draw your own

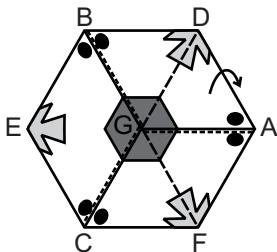

5. To change the pattern, collapse along five creases radiating from

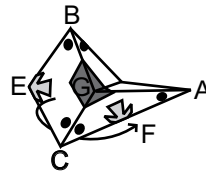

6. Fold E behind to touch F.

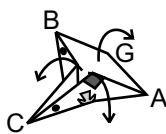

7. If you open out at the top.

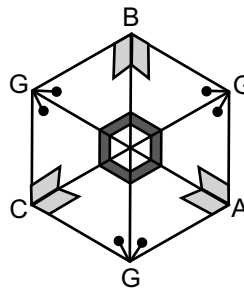

8. Then you will see a different pattern. Keep flexing and decorating.

9. Turn over. Continue to flex and decorate. Once you learn to change the patterns, you can also make a coloured picture book of your own.

FANTASTIC FLEXAGON

The Flexagon is a rotating paper model. As you flex it, each time a different picture comes into view. It can be used to depict any four stage cycle or sequence. It is simply unbelievable that paper can rotate like this without tearing.

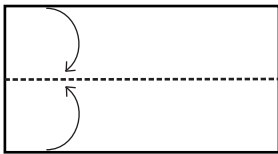

1. Take a 20 cm x 10 cm sheet of Xerox paper. It will have two squares.

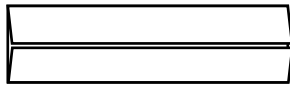

2. Crease long edges to midline.

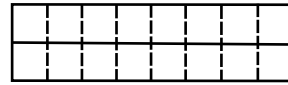

3. Fold 8 equal segments along the width.

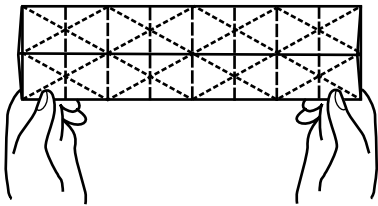

4. Draw and crease 10 slant lines with pencil and scale.

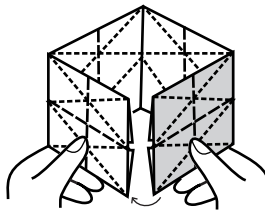

5. Tuck the shaded two-sections in the left hand pocket to lock and make a prism.

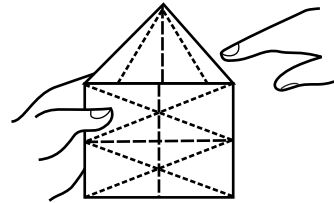

6. Push top and bottom triangular flaps inwards.

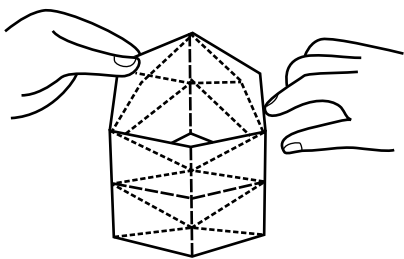

7. Tucking the flaps inwards will complete the Flexagon!

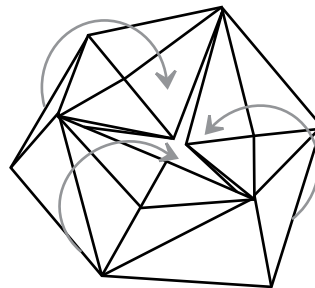

8. Hold the flexagon with both hands and rotate it. Soon all its four different surfaces will be exposed. The Flexagon can be used to depict the Food Chain and other cycles like the various seasons, life cycles of a butterfly etc.

PAPER BALL

Make a Paper Ball using 20 Hexagons.

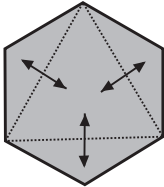

1. Take a hexagon and fold every other one of its corners to the centre. Make firm creases, then let the little triangular flaps so formed stand at right angles to the main area. Do the same with four more pieces.

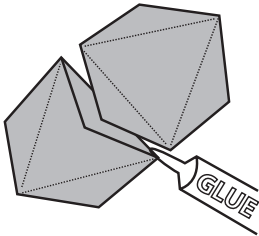

2. Join two pieces by gluing the outer sides of two flaps together.

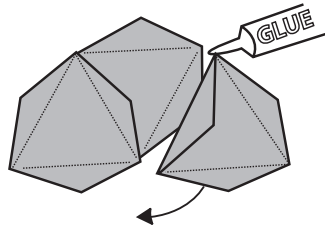

3. Similarly glue a third piece to the first two.

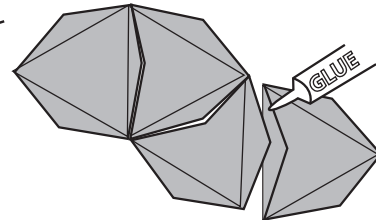

4. Add two more pieces. The fifth piece will be glued to the first piece...

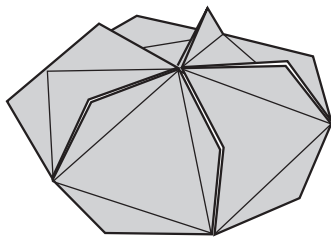

5. ... to complete a standing structure which has five triangular sides with little flaps in between.

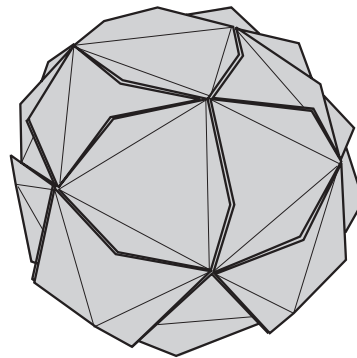

The completed 20 piece ball!

6. Now glue the remaining 10 hexagons together in line. Note that the first three pieces are joined as shown in step 3 but the fourth piece is differently placed. Glue the two ends of the chain together. Then glue the top and bottom sections in place to complete the Ball.

STRIP TETRA

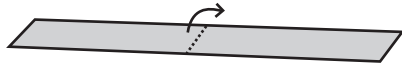

1. Fold a paper strip 28 cm x 4 cm in half. Bring the free ends together



2. ... and tape them.

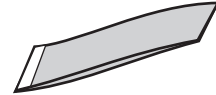

3. Bring the taped end to one side.



4. Fold again in half.

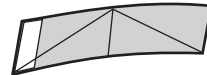
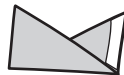
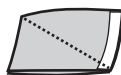

5. Fold mountain/valley along diagonals. Open the model.

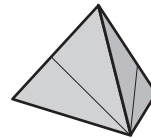
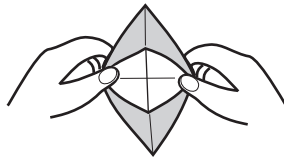
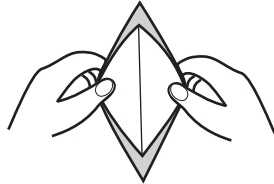

6. Open up like a boat. Bring the two edges together to complete the Tetrahedron!

BROOMSTICK STRUCTURES

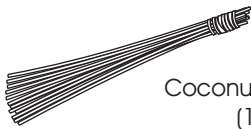

Coconut broomsticks
(15-cm)



Thread

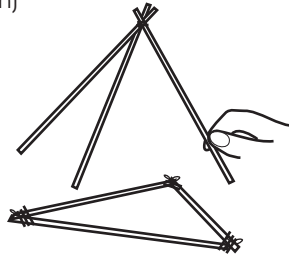
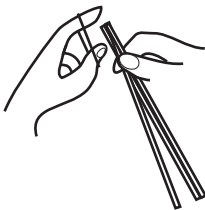

Make a Tetrahedron by tying three broomsticks to the vertices of an equilateral triangle.

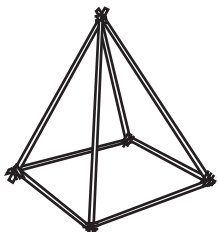

Make low-cost structural models by tying broomsticks with thread. For example make a Pyramid and Cube.

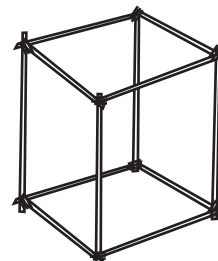

SELF LOCKING CUBE

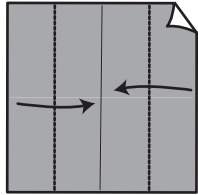

1. Fold opposite edges of a square to the mid-line.

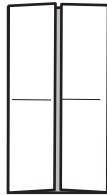

2. This will be the cupboard fold.



3. Bisect the top left angle in half.

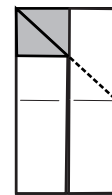

4. On opening you'll find a small triangular flap.

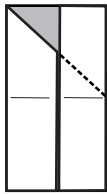

5. Fold and tuck the flap inwards.



6. Insert right corner inside the left vertical rectangle.

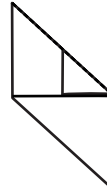

7. Repeat for the lower left corner. Bisect bottom right angle.

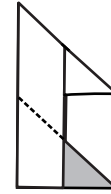

8. Fold the small triangular flap inwards.

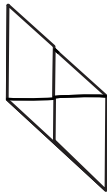

9. Insert bottom left corner to make a self-locked parallelogram.

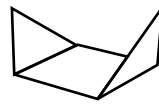

10. Invert and fold two triangular flaps. The base of the square will have four pockets.

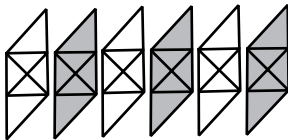

11. You will need six similarly oriented parallelograms.

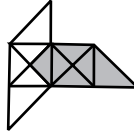

12. Tuck the flap of one parallelogram in the pocket of the other.

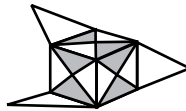

13. Assemble so that all flaps tuck in the pockets to make a No-Glue CUBE.

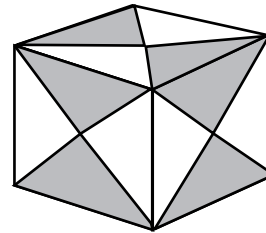

CRYPTOGRAMS

Here are some tough puzzles. Instead of numbers you've got letters! Each letter stands for a digit from 0 to 9. The challenge is to find out what each letter stands for and do the sums! (For answers see page 9)

1. $\begin{array}{r} \text{BOYS} \\ + \text{BOYS} \\ \hline \text{SILLY} \end{array}$	2. $\begin{array}{r} \text{GIRLS} \\ + \text{GIRLS} \\ \hline \text{SILLY} \end{array}$	3. $\begin{array}{r} \text{ARCS} \\ + \text{BRAS} \\ \hline \text{CRAS S} \end{array}$	4. $\begin{array}{r} \text{LLAMA} \\ - \text{SEAL} \\ \hline \text{SEAL} \end{array}$
5. $\begin{array}{r} \text{LIP} \\ + \text{LIT} \\ \hline \text{PIPE} \end{array}$	6. $\begin{array}{r} \text{PEP} \\ + \text{PEP} \\ \hline \text{ERNR} \end{array}$	7. $\begin{array}{r} \text{GOOD} \\ + \text{DOG} \\ \hline \text{FANG S} \end{array}$	8. $\begin{array}{r} \text{TOO} \\ \text{TOO} \\ \text{TOO} \\ + \text{TOO} \\ \hline \text{HOT} \end{array}$
9. $\begin{array}{r} \text{HER} \\ + \text{HURL} \\ \hline \text{SELLS} \end{array}$	10. $\begin{array}{r} \text{SPIT} \\ + \text{SIP} \\ \hline \text{TIPS} \end{array}$	11. $\begin{array}{r} \text{PET} \\ \text{PET} \\ + \text{PET} \\ \hline \text{TAPE} \end{array}$	12. $\begin{array}{r} \text{SEND} \\ + \text{MORE} \\ \hline \text{MONEY} \end{array}$
13. $\begin{array}{r} \text{STILL} \\ \text{STALL} \\ + \text{STILT} \\ \hline \text{NITWIT} \end{array}$	14. $\begin{array}{r} \text{EIGHT} \\ + \text{EIGHT} \\ \hline \text{TATTOO} \end{array}$	15. $\begin{array}{r} \text{ONE} \\ + \text{ONE} \\ \hline \text{ZERO} \end{array}$	16. $\begin{array}{r} \text{THIS} \\ \text{IS} \\ + \text{VERY} \\ \hline \text{EASY} \end{array}$
17. $\begin{array}{r} \text{CROSS} \\ + \text{ROADS} \\ \hline \text{DANGER} \end{array}$	18. $\begin{array}{r} \text{METRE} \\ \text{LITRE} \\ + \text{GRAMS} \\ \hline \text{METRIC} \end{array}$	19. $\begin{array}{r} \text{JUNE} \\ + \text{JULY} \\ \hline \text{APRIL} \end{array}$	20. $\begin{array}{r} \text{THREE} \\ \text{THREE} \\ + \text{FOUR} \\ \hline \text{ELEVEN} \end{array}$

TESSELLATIONS

A tessellation is the tiling of a plane surface using one or more geometric shapes, called tiles, with no overlaps and no gaps. Historically, tessellations were used in Ancient Rome and in Islamic art such as in the decorative tiling of the Taj Mahal. In the 20th century, the work of **M. C. Escher** often made use of tessellations for artistic effect. The arrays of hexagonal cells in honeycombs are tessellations.

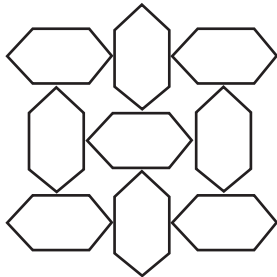

A floor tiling pattern from the Taj Mahal

The famous artist M. C. Escher (1898-1972), whose art is a source of inspiration to many mathematicians, had studied patterns made on the walls of Alhambra in Spain. About those special patterns, he says in his book: "This is the richest source of inspiration I have ever stuck. A surface can be regularly divided into, or filled up with, similar shaped figures which are contiguous to one another, without leaving any open spaces."

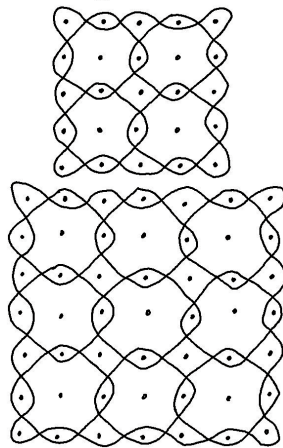
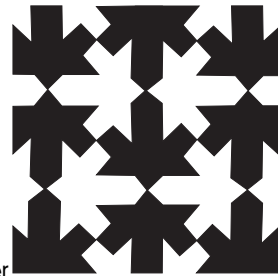

FOLK ART OF KOLAM



Kolam is a 5000-years-old and popular visual folk-art of Tamil Nadu. Kolam patterns are made on the main entrance to the house or the floor at the place of worship.

The designs are made with admirable ease. The ingredients used are rice flour or powdered quartz (a kind of white stone). Hence it is generally white in colour. The flour is taken between the thumb and the forefinger and dots are made before the lines are drawn. The designs are produced using a grid of dots.

SIMPLE TESSELLATION

Here's a simple example of how to play around with a simple tessellating shape to make a more complex, yet, another tessellating pattern:



1. First draw a square.

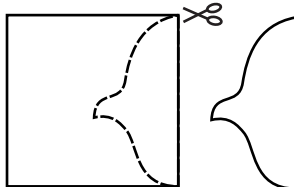

2. Cut a section from one side of the square. It doesn't matter what shape you cut out.



3. Add that section to the other side. Draw a picture to fill the new shape.

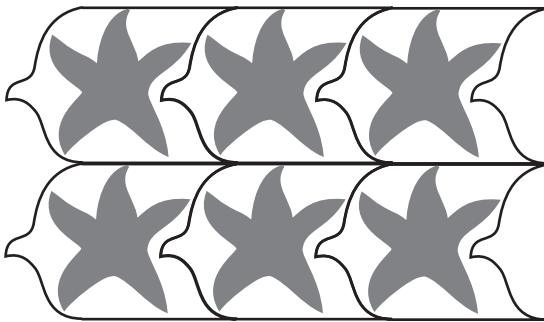

4. Copy the shape again and again to build up your tessellation. Try new patterns on your own.

SQUARE UP!

Copy these shapes on to another card sheet. There is something special about these shapes. Now, with just one cut you should be able to divide the shape into two pieces and then put the two pieces together to make a square!

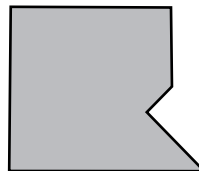
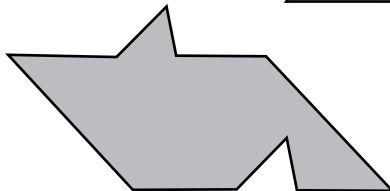
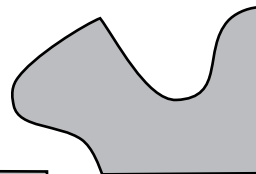
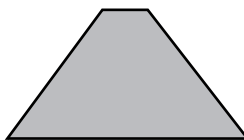

THE HEIGHT OF IT!

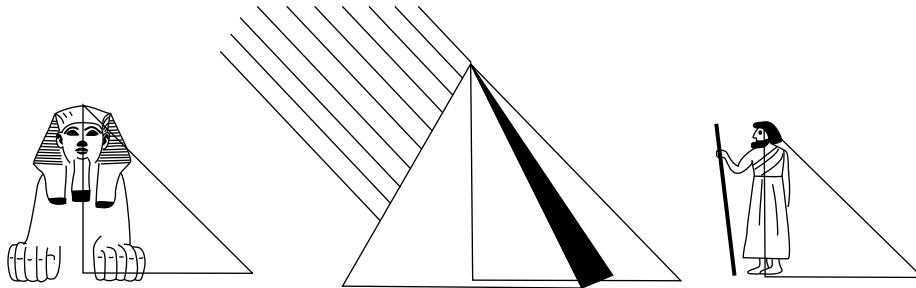

Thales (c. 624 BC – c. 546 BC) was a Greek philosopher from Miletus in Asia Minor. Thales rejected the mythological interpretation of the world and was a pioneer of the scientific revolution. Once he went for a sightseeing trip to Egypt. In the desert at Giza, he visited the three pyramids and the Sphinx half-buried in the sand nearby. During the year 600 B.C. when Thales visited the pyramids they were about 2000 years old.

"How high is this pyramid?" Thales asked the guides.

The guides were dumbfounded. They had no clue. No sightseer had ever asked them such a question. Thales pondered at the height of the Great Pyramid. He noticed that the sun's shadow fell from every object in the desert at the same angle. Since this was true, the sun's shadow created like triangles from every object. He calculated the height of the Great Pyramid by the length of its shadow, relative to the length of his own shadow.

Thales saw that at a certain time of the day, the length of his shadow equalled his own height. So, to calculate the pyramid's height, he measured its shadow at the same time of the day. Did Thales actually measure the height of the Great Pyramid at all?

It is impossible to say for sure, but the idea of measuring the height of such a tall object using only its shadow was so beautiful and striking that it still continues to delight and inspire. The Great Pyramid of Giza is approximately 139-meters high.

PLACE VALUE SNAKE

This splendid teaching aid is made from a strip of paper. When you open up the snake then you see the actual place values of all the numerals.

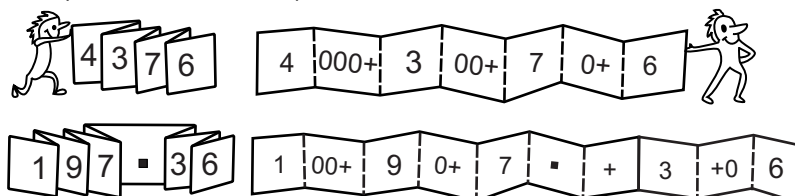

DIAGONAL OF A BRICK

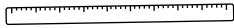
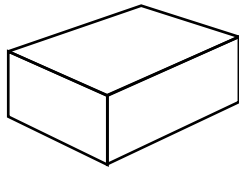

How can you use a ruler to find the length of the long diagonal—from one corner of the brick to its opposite corner? The solution is surprisingly simple. First place the brick at the corner of the table and then move it along equal to its length. The length of the diagonal from A to B can then be easily measured.

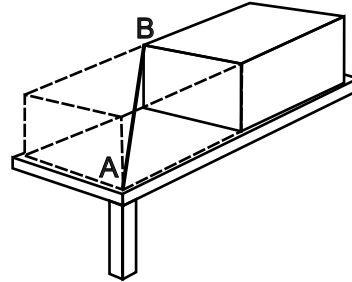

CATCHING CROOKS



Police sometimes locate criminals by triangulating signals from their mobile phones. First, the phone company traces the phone's unique signal. Then, they find out which three phone masts are nearest to that signal.

The strength of the signal between each mast and the phone can pinpoint the phone's exact location.

MAPS AND SURVEYS

A new system for finding places on maps was invented by French mathematician Rene Descartes in the 17th century. In his system, any point on the map can be described by its distance, along a horizontal one (the X-axis) and a vertical line (the Y-axis) from a particular point. These are known as **CARTESIAN COORDINATES**.

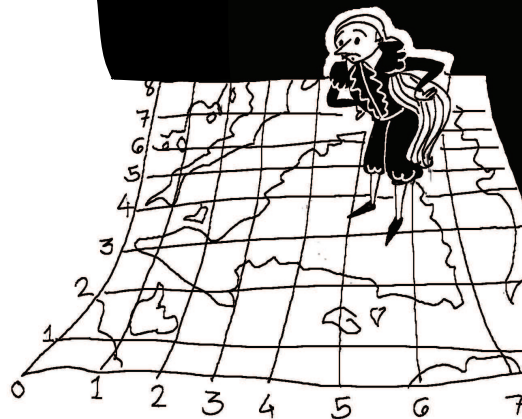

WHICH HOLDS MORE?

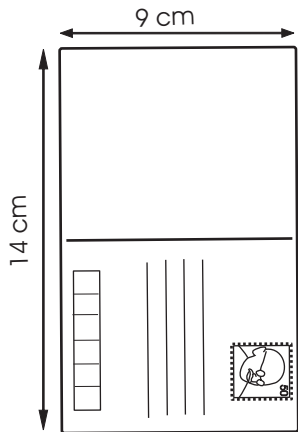

Postcards in India measure 14 cm x 9 cm. Fold two cylinders from two postcards by bringing their long and short edges together and taping them. You will get a thin but tall (14 cm tall) cylinder. Also a fat, short cylinder (9 cm tall).

Both cylinders will have the same surface area. Now, ask your friends: "Which cylinder will hold more sand?"

Most will say that both cylinders will hold the same amount of sand. But on testing they will be in for a surprise. Fill the thin, tall cylinder with sand to the top. Then slide the fat cylinder on the thin one, shake the thin cylinder and remove it. This way you can easily compare the volumes of sand they contain.

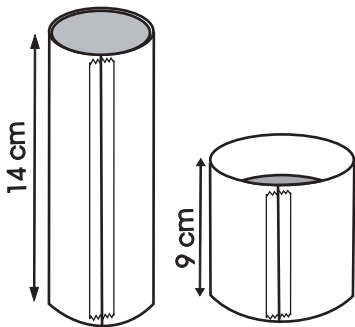

The fat one will be only two-third full! Why? The volume of a cylinder depends on the square of the radius and its height. As the fat cylinder has a larger radius, the square of the radius makes it a lot more capacious.

UNDERSTANDING THE UNIVERSE

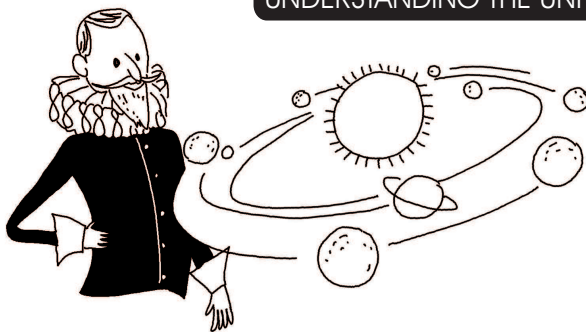

In the early 17th century, German mathematician and astronomer **Johannes Kepler** experimented with shapes and worked out how the planets and the Sun relate to each other.

He came up with the theory that planets orbit the Sun in elliptical (or oval)—not circular—paths. His discoveries helped later astronomers to predict how planets and their moons move through space.

THINKING OUTSIDE THE BOX

Some 'tricks' or puzzles can be used to help children realise the importance of looking at things in new ways—of going beyond the limits their own minds have set. Here is an example.

Draw 9 dots on a paper, on the blackboard, or in the dust, as shown. Ask everyone to try to figure out a way to connect all the dots with 4 straight lines joined together (drawn without lifting the pencil from the paper).

You will find that most people will try to draw lines that do not go outside the imaginary square or 'box' formed by the dots. Some may even conclude that it is impossible to join all the dots with four lines.

You can give them a clue by saying that, to solve the puzzle, they must go beyond the limits they set for themselves.

At last someone will probably figure out how to do it. The lines must extend beyond the 'box' formed by the dots.

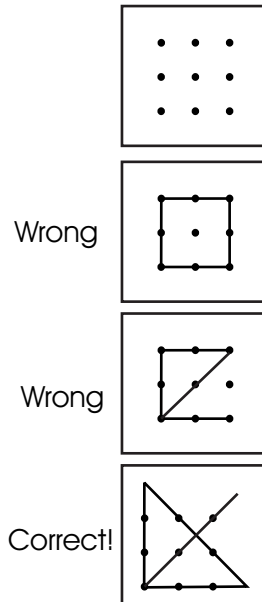

NUMBER PATTERNS WITH DOTS

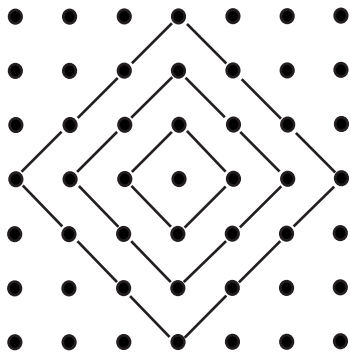

Make a pattern and count:
 The number of dots on the perimeter of each square:
 4, 8, 12...
 The number of dots inside each square: 1, 5, 13...

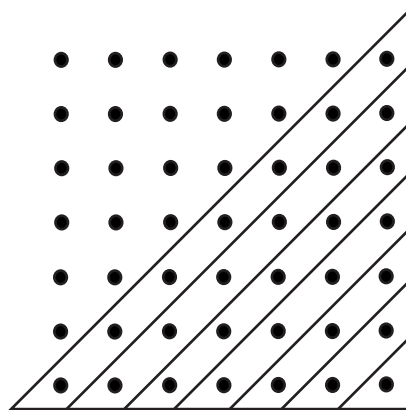

Triangular numbers are formed by making a sequence of right angled triangles as shown and counting the number of dots in each triangle.
 1, 3, 6, 10 ... How many dots would there be in the 12th triangle?

CATS AND MATS

*Once some cats
found some mats.
But if each mat
had but one cat
there'd be a cat
without a mat.*

*Should each mat
now have two cats
there'd be a mat
without a cat.
How many cats
and how many mats?*

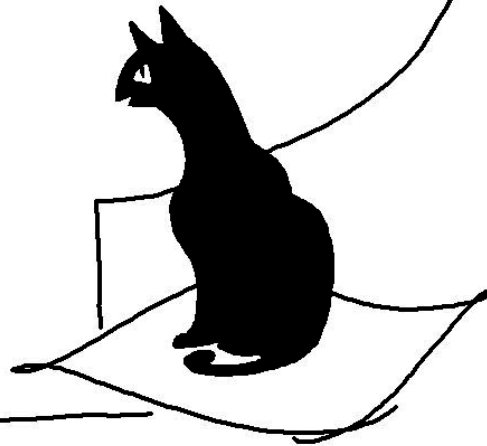

Figure out how many more cats would be needed to occupy all the places on the mats the second time, than to get the situation we had the first time? This is simple: in the first case one cat was left without a place, whilst in the second case all the cats were seated and there was place for two more.

Hence for all the mats to be occupied in the second case there should have been $1 + 2$; i.e. three, more cats than there were in the first case. But then each mat would have one more cat. Clearly there were three mats in all. Now we seat one cat on each mat and add one more to get the number of cats, i.e. four. Thus, the answer is Four cats and Three mats.



PALINDROME

A Palindrome is usually defined as a word, sentence, or set of numbers that spell the same backward as well as forward. The term is also applied to integers that are unchanged when they are reversed. Both types of palindromes have long interested those who amuse themselves with number and word play.

Let's take an example. Take 132 for instance. It is not a palindrome. But reverse it and add it to itself.
 $132 + 231 = 363$

Sometimes it may take much longer for you to get to a Palindrome. Take the number 68 for instance.
 $68 + 86 = 154$
 $154 + 451 = 605$
 $605 + 506 = 1111$

For all two-digit numbers if the sum of their digits is less than 10, the first step gives a two-digit palindrome. If their digits add to 10, 11, 12, 13, 14, 15, 16, or 18, a palindrome results after 2, 1, 2, 2, 3, 4, 6, 6 steps respectively. You may check this yourself, and also entertain yourself in the process!

There are some word Palindromes too. Like:

DAD
RADAR
EVIL OLIVE
MADAM I'M ADAM
DO GEESE SEE GOD?
NEVER ODD OR EVEN
MA IS A NUN AS I AM
A DOGI A PANIC IN A PAGODAI
CIGAR? TOSS IT IN A CAN, IT IS SO TRAGIC



SIMPLE CONSERVATION



Lump of
Clay



Make four clay balls of the same weight and size.

Then transform each ball into a different shape—animal, cube, cup and a saucer.

Ask your friend, "Which shape is heavier?"
Each shape was made from a similar ball, so how can they have different weights?

REMEMBERING THE VALUE OF PI

If you need to remember Pi, just count the letters in each word of the sentence,



You get two more decimal places. (3.141592653.....)

PARTS OF A CIRCLE

Here is a very simple way to label the parts of a circle.
You will need two card sheet circles, glue and a pen.

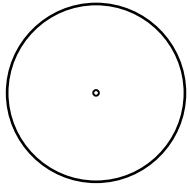

Cut two circles of 10 cm diameter from thin card sheet.

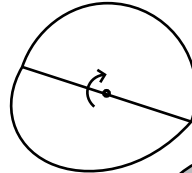

Fold them along the diameter.

Stick the top halves of both circles together. The lower half of the top circle can be lifted like a flap.

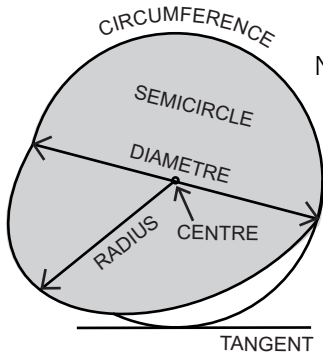
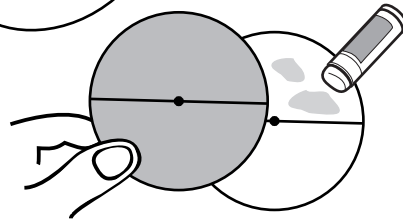

Now label the top circle.

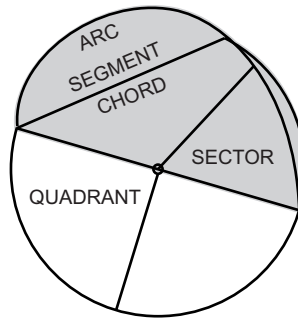

Lift the bottom flap and label the lower circle.

WHICH HOLDS MORE?

Suppose these six containers were set outside to measure rainfall.
Which container would collect the smallest amount of rain?
Which will fill up first?





A TRICKY CIRCLE

Can you draw a circle and its centre without lifting the pencil? It looks impossible but it can be done.

Fold the right corner of the paper, as shown. Start with the centre of the paper from the folded corner and then proceed to draw the whole circle.

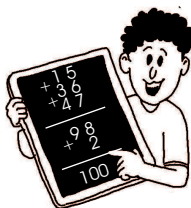

ADD TO HUNDRED

Here are digits from 1 to 9 arranged so they equal 100. Can you find another way to do this?

What rule was followed when these numbers were arranged?

MEASURING OUT

You have two measures of 4 litres and 7 litres and a bucketful of milk. How will you give 2 litres of milk to a customer?



HOW MANY DAYS IN FEBRUARY?

How many months have 28 days?

One. February.

Wrong. All 12 months have 28 days. Most have 2-3 days more.



LEGEND OF THE CHESS-BOARD

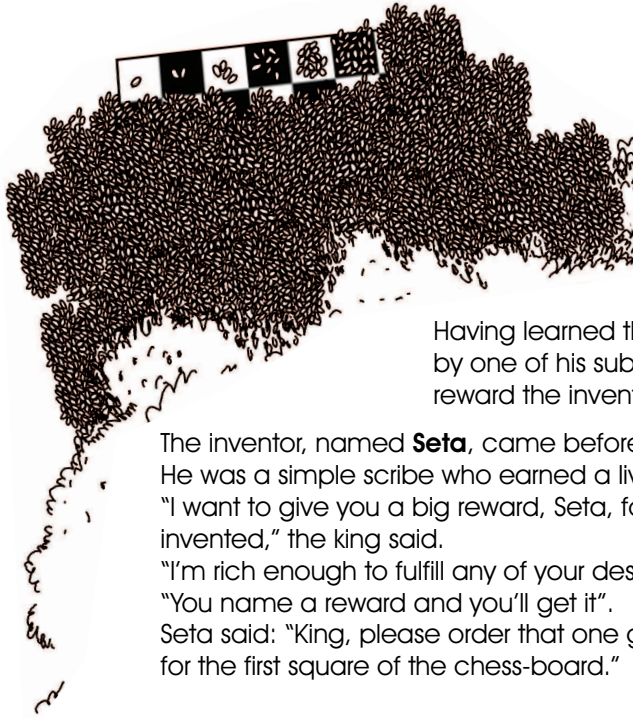

Chess, one of the world's most ancient games, was invented in India. The Indian king was amazed at its ingeniousness and the infinite variety of positions it afforded.

Having learned that the game was invented by one of his subjects, the king wanted to reward the inventor.

The inventor, named **Seta**, came before the king's throne. He was a simple scribe who earned a living giving lessons to pupils. "I want to give you a big reward, Seta, for the beautiful game you have invented," the king said. "I'm rich enough to fulfill any of your desires," the king went on to say. "You name a reward and you'll get it". Seta said: "King, please order that one grain of wheat be given to me for the first square of the chess-board."

"A simple wheat grain? That's all!" the king was shocked. "Yes, my lord. For the second square let there be two grains, for the third four, for the fourth eight, for the fifth 16, for the sixth 32 ... "Enough!" the king was exasperated. "You'll get your grains for all the 64 square of the board according to your wish." The court mathematicians went into an overdrive trying to calculate the number of wheat grains and came up with a prodigious number of 18, 446, 744, 073, 709, 551, 615 grains.

The first square will have 1, second 2, third 4, fourth 8, etc. The result of the 63rd doubling will be what the inventor should receive for the 64th square of the board. It was a huge amount. It's known that a cubic metre of wheat contains about 15,000,000 grains. Consequently, the reward of the inventor of chess would occupy about 12,000,000,000,000 cubic metres, or 12,000 cubic kilometres. If the barn were 4 metres high and 10 metres wide its length would be 300,000,000 kilometres, twice the distance to the Sun! The Indian king could never grant such a reward.

MATHEMATICAL PROOF

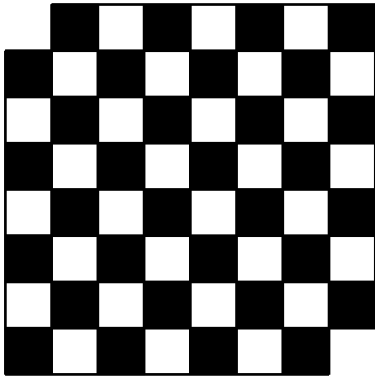

A problem could be solved scientifically or mathematically. Here we will see the difference.

Two opposite corners have been removed from a chess-board. So, instead of 64 only 62 squares remain. We have 31 dominoes—with one white and other black square. Will it be possible to cover the chess-board with 31 dominoes so that they cover all the 62 squares on the chess-board? Here are the scientific and mathematical ways.

(1) **Scientific Method:** A scientist would try to solve the problem experimentally. He will try all possible combinations to fill up the chess-board with 31 dominoes and will soon discover its impossibility. But how can he be dead sure about his claim? He tried out several combinations which did not work. But there would still be millions of other untried ways. Some combinations might actually work. Who knows? Maybe someday someone may discover the right combination and upturn the scientific theory.

(2) **Mathematical Method:** On the other hand the mathematician tries to answer the question by developing a logical argument. He will try to derive a sure shot correct conclusion which will be etched in stone and remain unchallenged forever. Here is a sample of the mathematical logic:

As the removed corners were both white, so there will now be 32 black and only 30 white squares left. Each domino can cover only two adjacent squares with different colours—one black and the other white. Therefore, no matter how they are arranged, the first 30 dominoes will cover only 30 white squares and 30 black squares. Consequently, this will always leave you with one domino and two black squares. But remember a domino covers two adjacent squares, and neighbouring squares are opposite in colour. Because, the two remaining squares are both of the same colour so they cannot both be covered by the one remaining domino.

Therefore, covering the board is impossible! This proof shows that every possible arrangement of dominoes will fail to cover the mutilated chess-board.

MIRROR PUZZLES

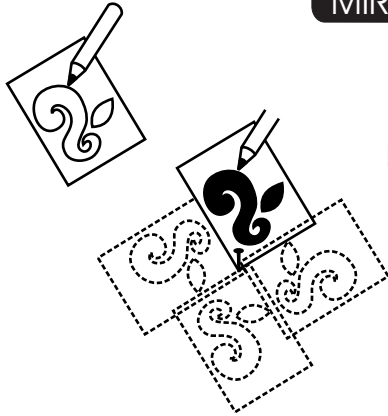

Draw and cut a pattern on a postcard. Push a pin in one corner and draw the pattern. Rotate a quarter turn and draw again. You will get a beautiful pattern showing rotational symmetry.

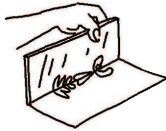

Draw a shape and put a mirror besides it so that the shape doubles itself.



Fold a paper in half. Cut a shape on its doubled edge. Open the paper to see a symmetric pattern. Which is the line of symmetry?

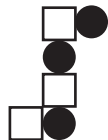
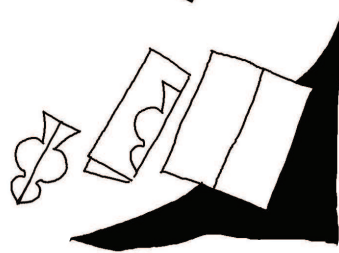

MASTER PATTERN

Stand your mirror on this master pattern each time, in different orientations, to get the rest of the patterns. You will be able to get most of them.

But some of the patterns have been included to trick you. They are not just hard, but simply impossible. Can you locate these? If you have enjoyed these mirror puzzles why not make some of your own.

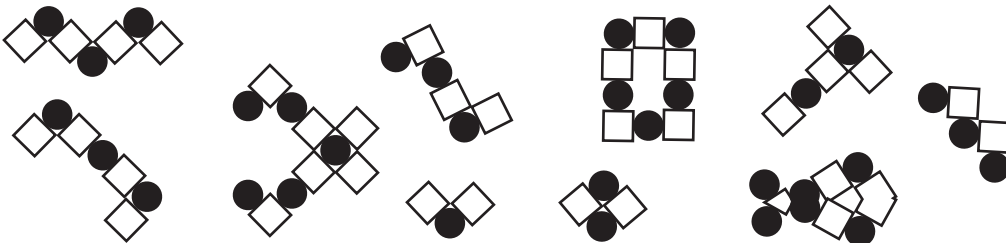

SHORTEST PATH

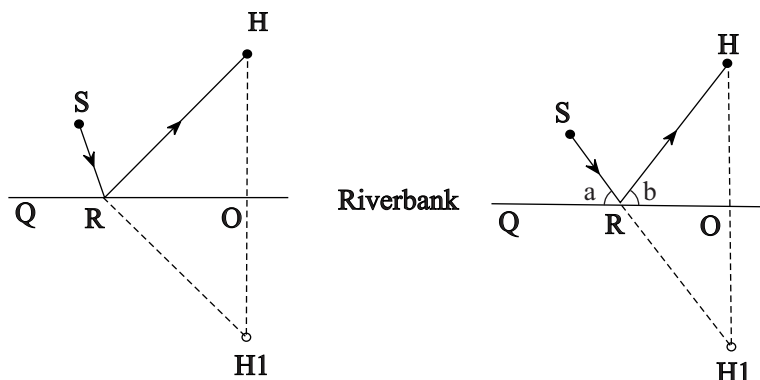
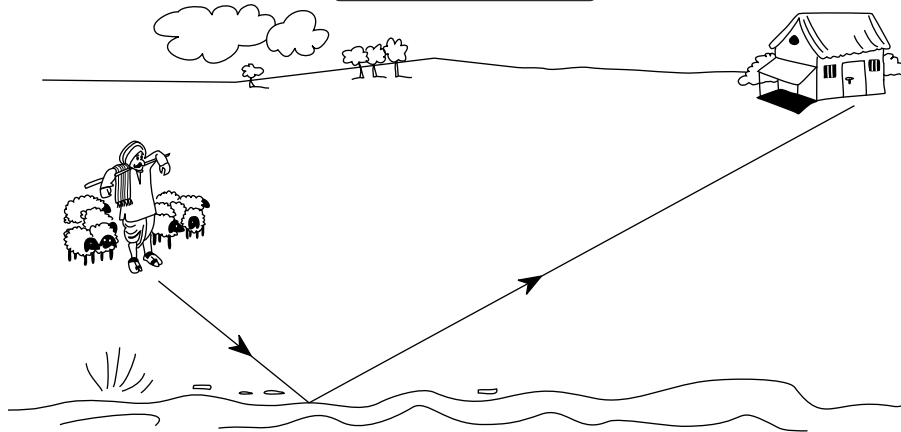

A shepherd is out grazing his sheep. At the end of the day he wants to take them to the river for a last drink of water before heading home. Which path should he take to minimise the travel to his home via the river? In other words which part of the river (R) should he pick so as to minimise the total distance home?

To minimise travel his path to the river and from there to his home should be such that they make equal angles with the river (Angle $a =$ Angle b).

To solve this problem imagine his hut H was at the same distance from the river bank but on the opposite side at H1. For whichever point R on the river bank the shepherd (S) stops at, the distances RH and RH1 will then be equal. How to pick point R? It should be chosen to minimise the distance $SR + RH1$. So, pick R so as to minimise $SR + RH$ is the same as picking up R so as to minimise $SR + RH1$.

The solution to this problem is simple. Choose R so that SRH1 is a straight line.

POSTMAN'S PROBLEM

Soap bubbles are often considered as playthings for children, but they can be fascinating for adults too. As soap bubbles always minimise their surface area they help solve many complex mathematical problems in space.

This is a very practical problem: A postman has to deliver letters to four towns A, B, C and D located at the vertices of a square.

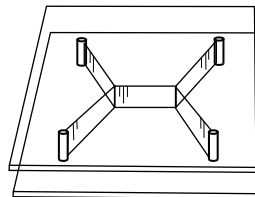
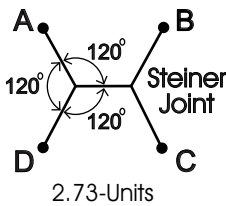
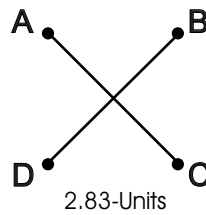
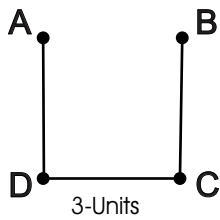
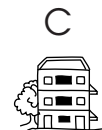
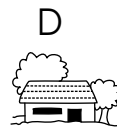
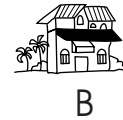

How to connect these towns so as to minimise the postman's beat? You can have a "U" shaped network of three straight lines with a total length of 3 units. A little trial and error will show that we do better by introducing an intersection point in the middle—essentially two lines in a "X" formation. As both diagonals of the unit square AC and BD will be 1.41, so the total length of the cross will be 2.83.

This of course raises the question of whether we might do better by introducing one more intersection point. But what should its location be? At what angle?

This is a very difficult question and one way of experimentally dealing with it is to use soap bubbles. Take two clear Perspex or acrylic sheets. Place them parallel to one another and affix four pins at the corners of the square. Now on dipping it in soap solution, each time you will get a soap film which minimises its surface area. You will find five straight lines with two 3-way intersections at an angle of 120-degrees. These 120-degree joints are called as Steiner Joints. The total length of this road will be just 2.73 units—the minimum distance joining the four towns. This also turns out to be the solution to the Postman's shortest beat.

MATCHSTICK MATCHING

Move only as many sticks as directed and create as many squares as requested. (Squares can overlap or have corners in common)

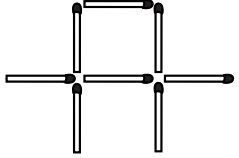
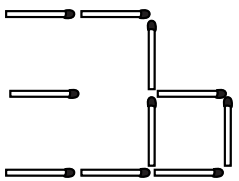
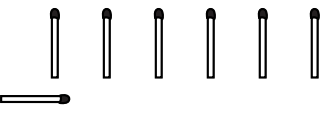
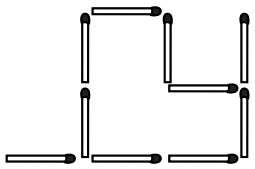
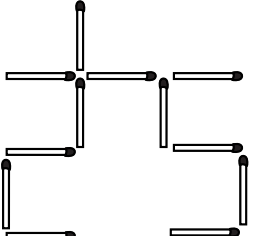
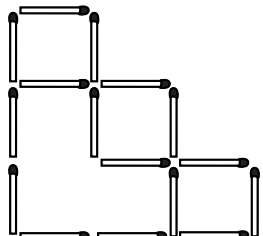
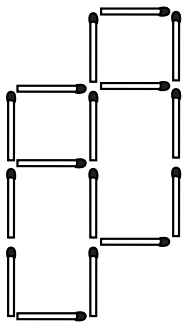
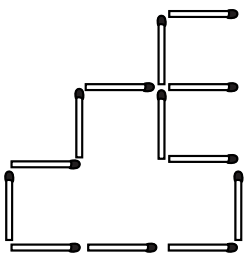
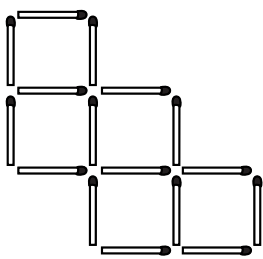
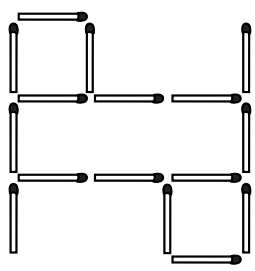
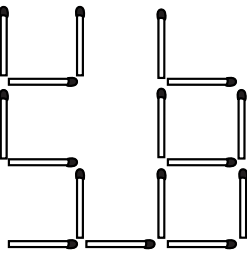
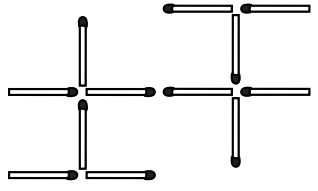
	CHANGE 2 STICKS	CHANGE 3 STICKS	CHANGE 4 STICKS
MAKE 2 SQUARES			
MAKE 3 SQUARES			
MAKE 4 SQUARES			
MAKE 5 SQUARES			

TANGRAM

Tangram is an ancient Chinese puzzle, which is essentially a square cut into seven pieces.

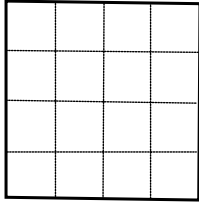

1. Make 16 small squares on a card square.

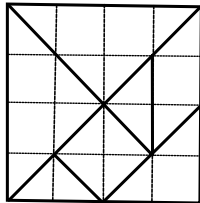

2. Draw lines as shown.

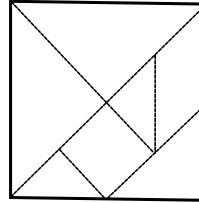

3. Cut along the lines to get seven pieces.

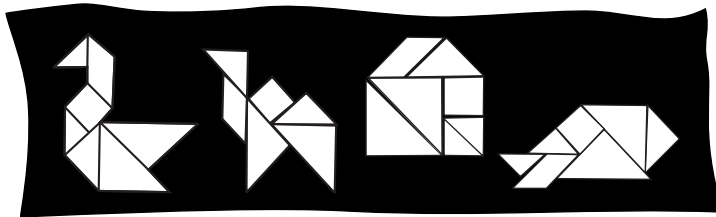

Then join all the seven pieces together to create different patterns—geometric designs, humans, birds, animals, etc. All the seven pieces have to be used for each design.

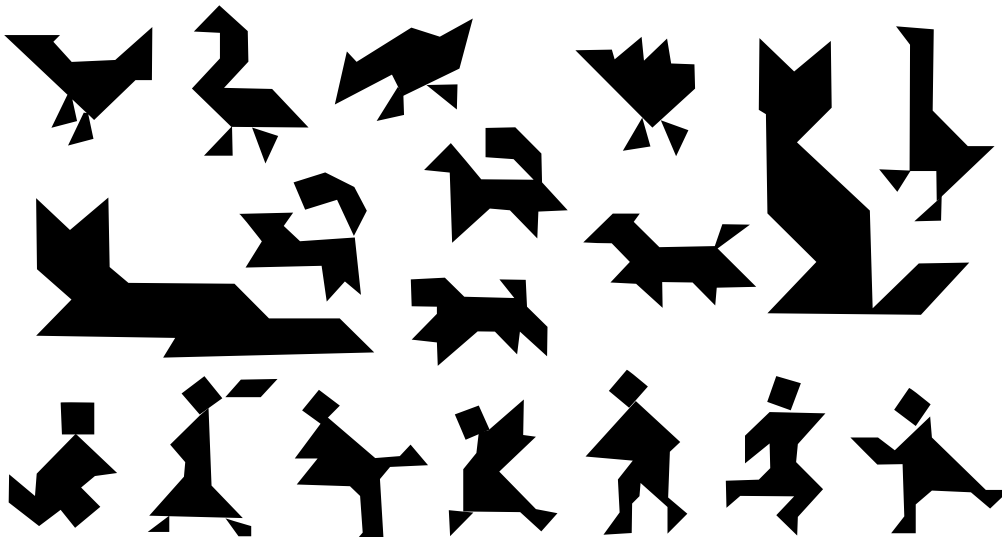

VALUE OF Pi

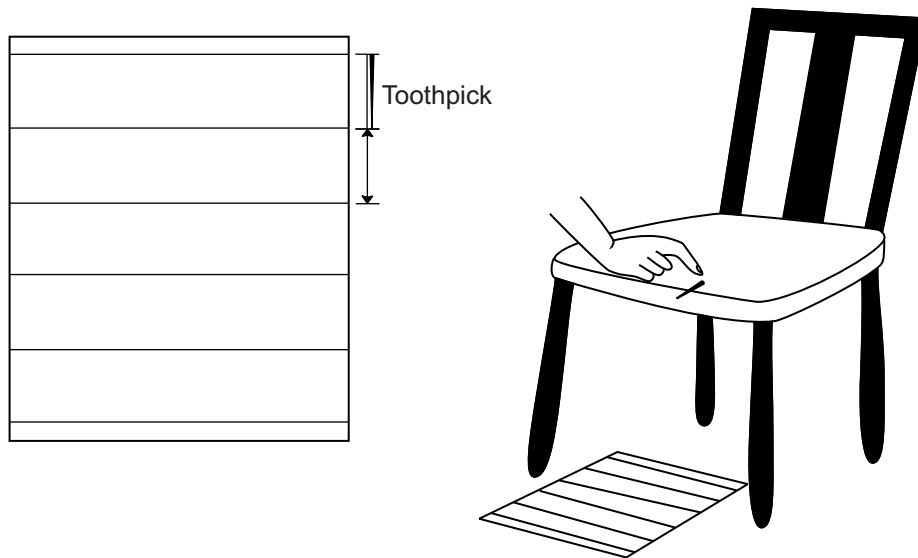

You could find the value of Pi (π) quite accurately by dropping toothpicks! Count Buffon did this interesting experiment. You can repeat it 300 years later. Make a series of parallel lines on a sheet of paper. The lines should be one toothpick apart. The toothpick will play a crucial part in this experiment. Hold the toothpick on the edge of a chair and let it fall onto the ruled paper, as shown here.

Record the number of times any part of the toothpick touches any line. Also note down the number of times the toothpick does not touch any line. **Count Buffon** found that if you drop the toothpick enough times, a definite relationship exists between the two possibilities.

The chance that the toothpick will touch a line is $2/3.14$ or $2/(\pi)$. We know that the circumference of a circle is equal to its diameter multiplied by Pi (π). The constant Pi (π) has been identified with a circle. Isn't it strange that the toothpick dropping experiment can help you find the value of Pi (π)?

An Italian mathematician Lazzarini dropped the toothpick 3408 times. The value of Pi (π) which he obtained was 3.1415929 ...

BIGGEST BOX

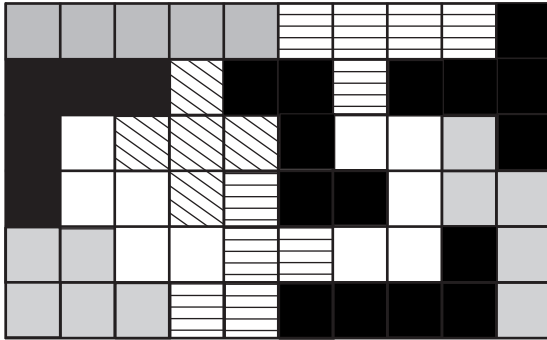

Make different patterns using 5 squares each time. There are only 12 known Pentaminos. Here they are fitted in a jigsaw to form a 10 x 6 rectangle. Cut them out from a piece of cardboard. Try fitting them to form 10 x 6, 12 x 5, 15 x 4 and 20 x 3 rectangles. There are thousands of solutions, but feel happy if you can find one for each rectangle.

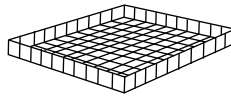
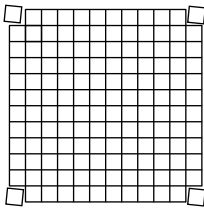
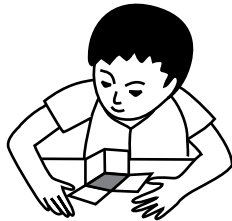
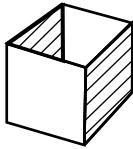

$$10 \times 10 \times 1 = \text{Volume } 100 \text{ cc}$$

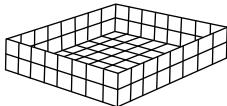
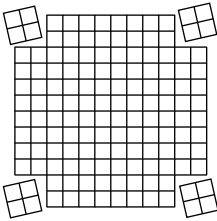

$$8 \times 8 \times 2 = \text{Volume } 128 \text{ cc}$$

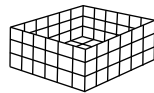
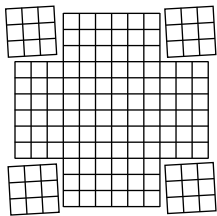

$$6 \times 6 \times 3 = \text{Volume } 108 \text{ cc}$$

In mathematics we are often confronted with problems of finding the SMALLEST or the BIGGEST.

For instance, given a 12 x 12 cm card sheet how to fold a box which will hold the most amount of water?

This is a challenging exercise and has a great appeal because some of the solutions are very amazing and satisfying. Some of the possible combinations of length, width and height in centimetres are as follows:

Volume = Length x Width x Height
 $L(12) \times W(12) \times H(0) = \text{Volume } 0 \text{ cc}$
 $L(10) \times W(10) \times H(1) = \text{Volume } 100 \text{ cc}$
 $L(8) \times W(8) \times H(2) = \text{Volume } 128 \text{ cc}$
 $L(6) \times W(6) \times H(3) = \text{Volume } 108 \text{ cc}$
 $L(4) \times W(4) \times H(4) = \text{Volume } 64 \text{ cc}$
 $L(2) \times W(2) \times H(5) = \text{Volume } 20\text{-cc}$
 $L(0) \times W(0) \times H(6) = \text{Volume } 0\text{-cc}$

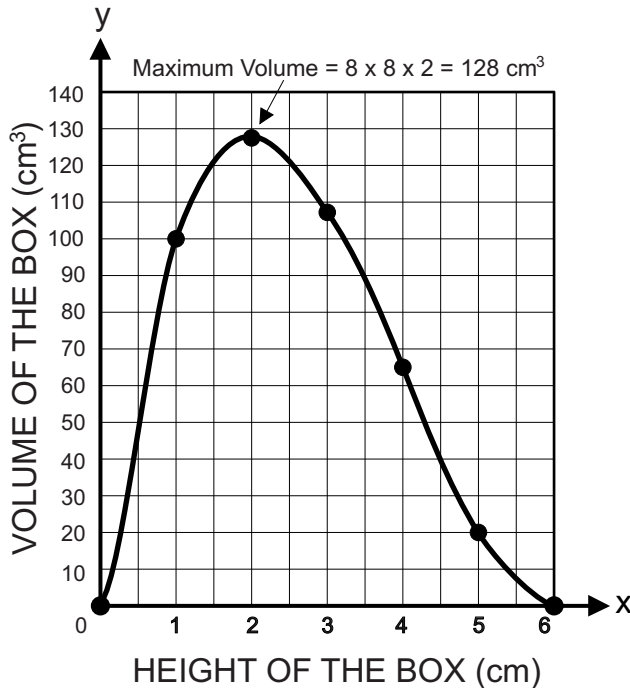

This experiment gives a wonderful feel about Differential Calculus. When the height is 1 cm, the volume is 100 cc. With height 2 cm, volume is 128 cc, which is the maximum. With height 3 cm, volume drops to 108 cc. The inflexion point occurs when height is 2 cm.

The graph shows that if the height of the box is represented by (a) and the volume by (b). Its base has a side of (12-2a).

The volume of the box can be calculated by using the formula:

$$\begin{aligned}
 \text{Volume} &= \text{Length} \times \text{Width} \times \text{Height} \\
 &= (12-2a) \times (12-2a) \times a \\
 &= (144 - 24a - 24a + 4a^2) \times a \\
 &= (144a - 48a^2 + 4a^3)
 \end{aligned}$$

The differentiation (dy/dx) finds the gradient
 $dy/dx = 144 - 96a + 12a^2$

The gradient will be Zero at the maximum and minimum turning points on the graph, This is when the $dy/dx = 0$, giving the maximum and minimum volume.

$$144 - 96a + 12a^2 = 0$$

On solving we get $a = 6$ and $a = 2$.

So, the maximum volume 128 cc of the box will be when its length and width are 8 cm and the height is 2 cm.

Mark six different shapes on a dice. Cut 10 cardboard cutouts each of every shape and put them in a bag. Roll the dice. Feel the bag for the shape that appears on the top face of the dice. If you pull the right shape, you keep it. Take turns.

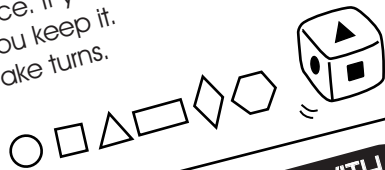

Each person draws four boxes like this:

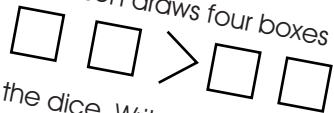

Roll the dice. Write the number shown on the dice in any one of the boxes. Once put, you can't change its position. Roll the dice until all the boxes are full. Is the left hand number greater than the right hand number? If it is then you collect a counter. The first person to collect five counters wins.

FUN WITH DICES

For this game you require three dices and a paper and pencil to record your score. Throw all three dices together. Add the dots on the top surfaces of all the three dices. The player to score a grand total of 100 is the winner.



A player tosses two dices twice. She adds the dots on the top surface of each dice on every throw. Then she multiplies them. The correct answer wins 1 point.
For eg.
 $6 \times 9 = 54$

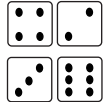

After each round, the player with the highest score gets a point. The player who scores 10 points first is the winner.



VARIATION
Children can change the rules and make various games using three dices. They can throw all three dices together. Then add the two dices with the highest numbers and from this sum subtract the number on the third dice. This would be their score. They take turns and the player who scores 100 first is the winner.



BIRTHDAYS



There is a good chance that while attending a party you may find someone else with the same birth date as yours.

This problem is very counter-intuitive. Imagine two hockey teams with the referee. They will be a total of 23 people. What is the probability that any two of those 23 people share the same birthday?

With just 23 people and 365 birthdays to choose from, it may appear very unlikely that a pair may share the same birthday. Most people would guess a probability of perhaps 10 per cent at most. But in fact, the actual answer is just over 50 per cent. It means that, it is more likely than not that two people on a hockey field will share the same birth day.

While looking for a shared birthday, we need to look at pairs of people not individuals. Surprisingly, 23 people can make 253 pairs. For example, the first person can be paired with any of the other 22 people. This gives 22 pairs. The second person, in turn can be paired with any of the remaining 21 people giving 21 more pairs. The third person can be paired with any of the remaining 20 people, giving an additional 20 pairs. On adding all these we will reach a total of 253 pairs.

The fact that the probability of a shared birthday within a group of 23 people is more than 50 per cent seems intuitively wrong, and yet it is mathematically undeniable. Strange probabilities such as this are exactly what bookmakers and gamblers rely on in order to exploit the unwary. The next time you are at a party with more than 23 people you might want to make a wager that two people in the room will share a birthday. Please note that with a group of 23 people the probability is only slightly more than 50 per cent, but the probability rapidly rises as the group increases in size. Hence, with a party of 30 people it is certainly worth betting that two of them will share the same birthday!

PERFORATED SYMMETRY

A piece of paper was folded and punched just once with a paper punch. How can you fold and punch a paper so that it looks like the drawing when unfolded.

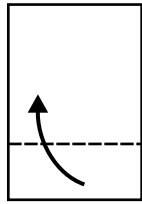

1. Fold the bottom edge of the paper one-third upwards.

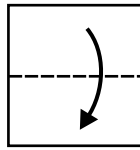

2. Fold the top edge one-third down.

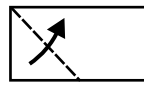

3. Fold corner up.

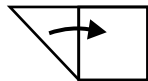

4. Fold point over.



5. Punch hole here.

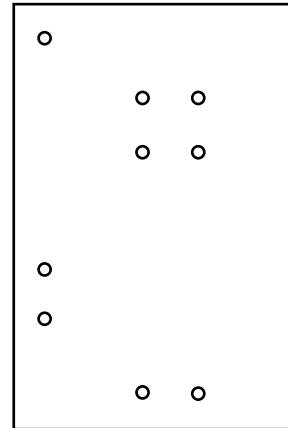

6. Open to see this pattern.

MATHS GRAPHICS

A picture says more than a thousand words. These delightful graphics will help you visualize these geometric figures.

CONE

BLOCK

parallel

SQUARE

A
D
+
D
—

TRAPEZIUM

ELLIPSE

ROUND

OVAL

HEXAGON

DIAMOND

FINGER MULTIPLICATION



This simple method of multiplication was used in Russia before the Russian Revolution. At that time people were poor and could not send their children to school. This is a simple way to multiply numbers from 6 to 10.

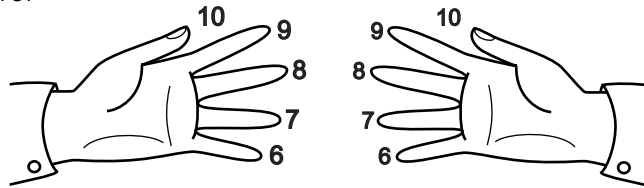

For this, give numbers to your fingers from 6 to 10 as shown.

If you want to multiply 7 by 8, finger number 7 of one hand must touch finger number 8 on the other hand. Then the two fingers together with all the fingers under them are tens. You have five tens, that is 50. Then you multiply the number of the other fingers on the left hand by the number of other fingers on the right hand. This gives you $3 \times 2 = 6$. Add 50 and 6 and this will give you the answer - 56. This method always gives the right answer.

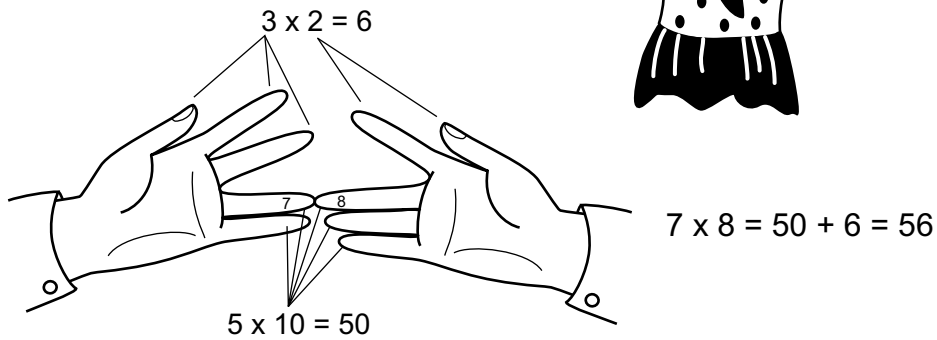

FRAC
TION

E^xPONENT

GRAPH

PENTAGON

DIVIDE

PYRAMID

THE EARTH'S CIRCUMFERENCE

Around 2,200 years ago **Eratosthenes**, an ancient Greek mathematician, used his knowledge of circles, triangles etc to estimate the circumference of the Earth.

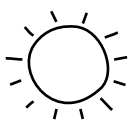

Eratosthenes lived in Egypt. He measured shadows cast by the sun.

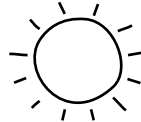

At precisely noon on a midsummer's day, the sun cast no shadow onto a sundial in Syene, a town in Southern Egypt.

But at exactly the same time in Alexandria, the sun cast a slim shadow onto a sundial.

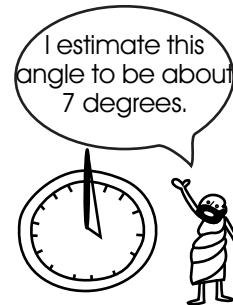
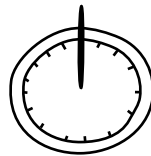

In those days distances were measured in units called Stadia (1 Stadia = 0.15 km). The distance from Alexandria to Syene was about 756 kms.

As the Earth was roughly circular, the arc between the towns was 7 degrees out of the total of 360 degrees, or approximately 1/50. So the distance between the towns was 1/50 of the total circumference of the earth.

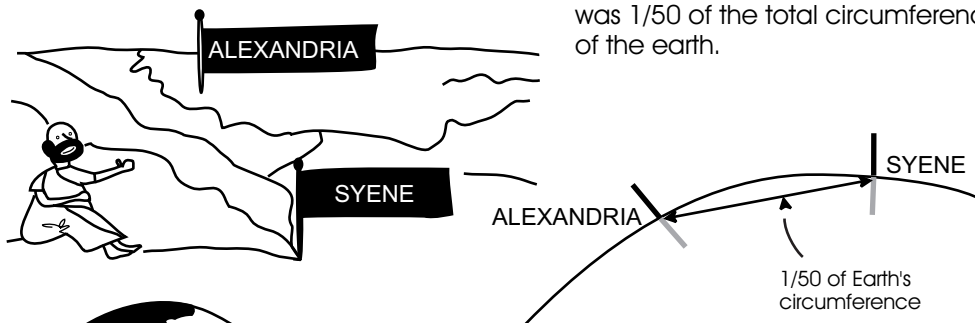

Eratosthenes estimated the Earth's circumference as 37,800 kms. Modern measurements give it as 40,075 kms. So, Eratosthenes's estimate was pretty good. This powerful idea demonstrated that one need not walk around the Earth to measure it. One could use a simple shadow to come to a great conclusion!

CYLINDER - CONE VOLUME

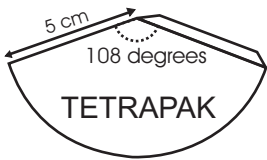

1. Cut a sector of a circle with radius 5 cm and an angle of 108 degrees. Fold and stick to make a cone.

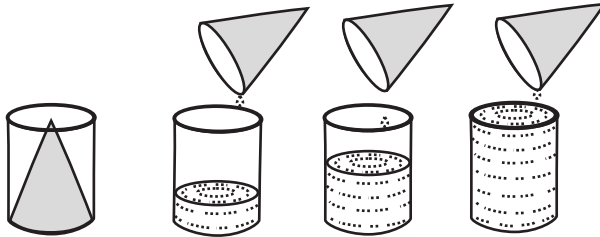

2. The cone will sit snugly into the cylindrical film reel bottle.

3. The cone and a cylinder will have the same base and height. The volume of the cylinder will be thrice than that of the cone. Test it by pouring three cone-fuls of water in the film bottle.

SQUARE TO TRIANGLE

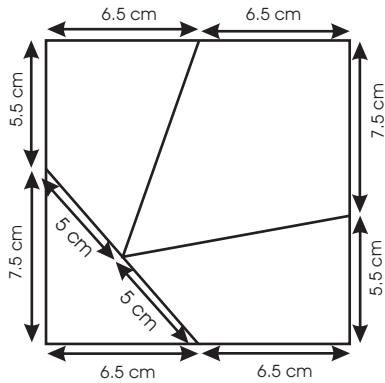

A 13 cm edge square of rubber shoe sole has been cut into four pieces here. All the pieces are hinged together with small strips of cloth and stuck with a rubber adhesive.

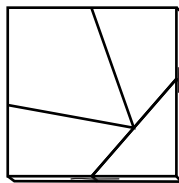
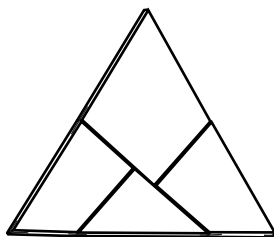
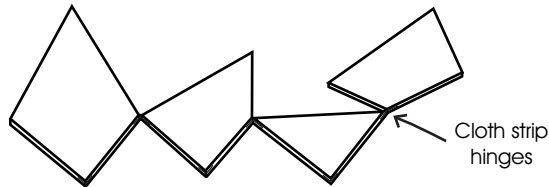

This arrangement could be easily turned around either to make an equilateral triangle or a square.

It is said that the great British puzzler **Dudney** had a table like this. If he had two guests (he was the third) he would have the configuration of a triangle. With three guests he would just turn around the table to make it a square so that four people could sit around.

Solutions to Matchstick Matching on page 47

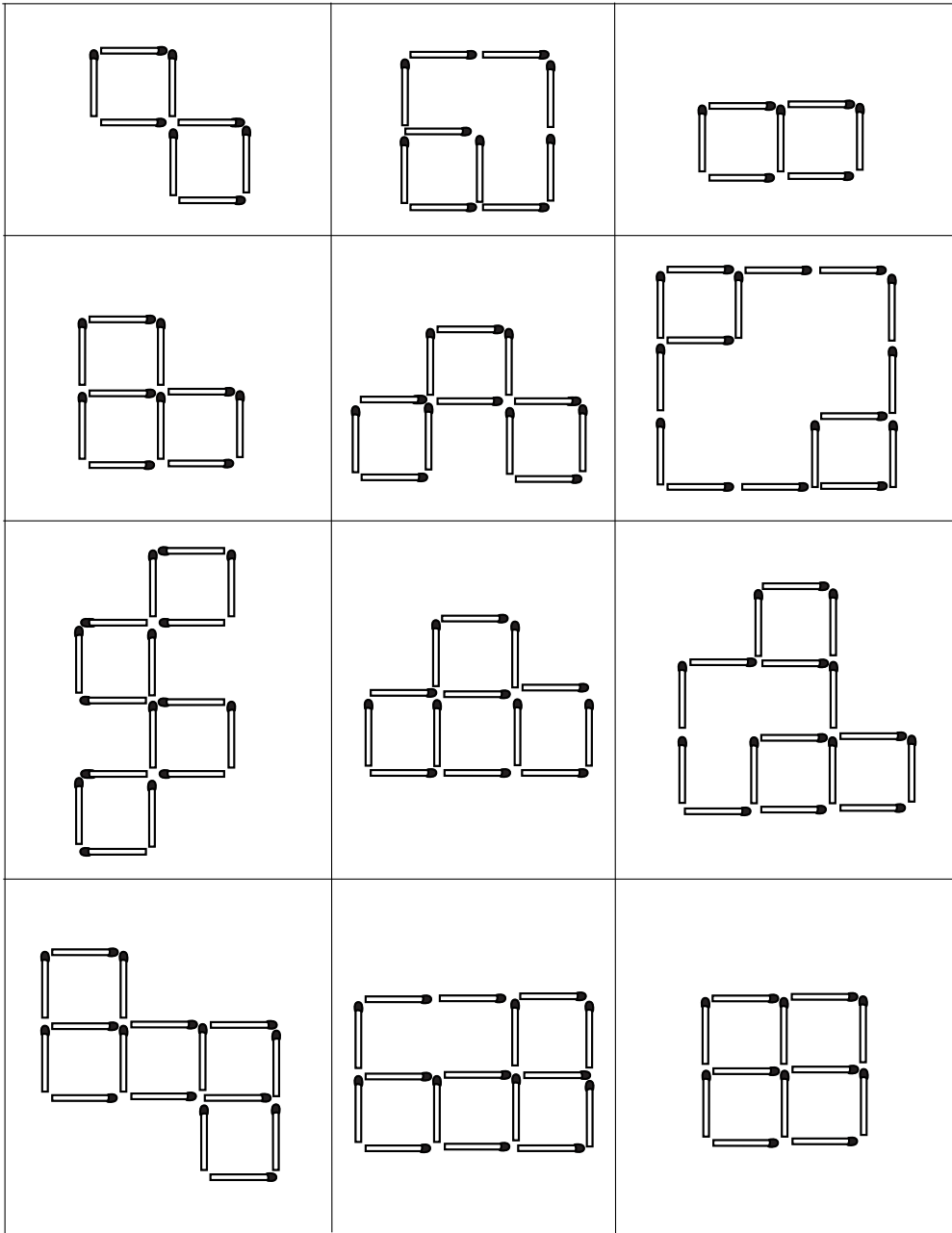

HANDS-ON MATHS

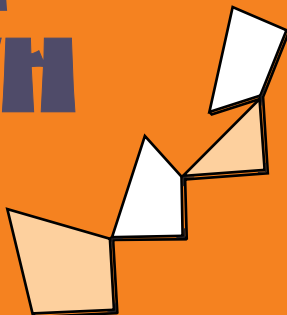
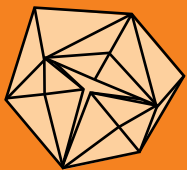

There is a saying:
Skills are taught
Concepts are caught

Children don't learn a concept by mechanically solving numerous bookish problems. Children learn a great deal of math through teasers, puzzles and activities. Problem solving helps them to figure out things and learn math. This book collates inspiring stories from the lives of mathematicians along with many creative activities which will give children a concrete feel for math.

